



Concrete Wash Basins

Nuance
STUDIO



LITHEOZ

Standing apart from the conventional concrete, Litheoz is a technologically advanced material, homogeneously blended to achieve a range of colours, along with fine textures. In technological terms, Litheoz is a ultra high performance fibre reinforced concrete (UHPFRC) carefully engineered to redefine the abilities of concrete. Resulting in a perfect blend of technology and allure.

Varied methodologies from traditional to modern techniques of mould making to casting is adopted by our designers at Nuance Studio. The rheology of Litheoz enables it to be cast into a mould by spraying, pouring, or injecting and even sculpted by hand. Perfecting this rapidly growing technology, Nuance has delivered a range of unique products in many verticals that demand products to be customizable & innovative.

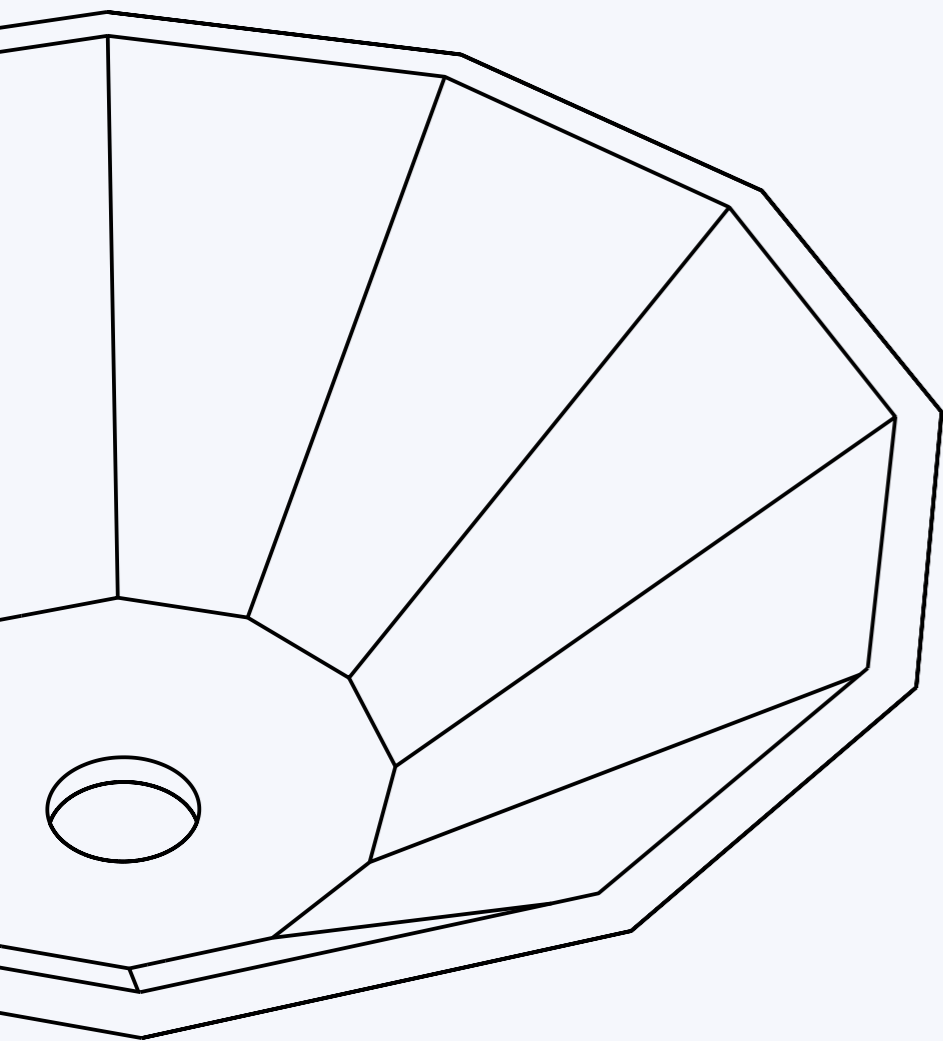

Exquisite Series

“Design Is Thinking Made Visual”

Wash basins offered by Nuance Studio are designed to resonate the true essence of modern design. Our basins echo the natural qualities of concrete, reflecting style, elegance and grandeur. Divided into three models, the Exquisite series wash basins offered by Nuance Studio are aesthetically designed to meet high standards of personalized luxury.



Orbed



Dimensions:

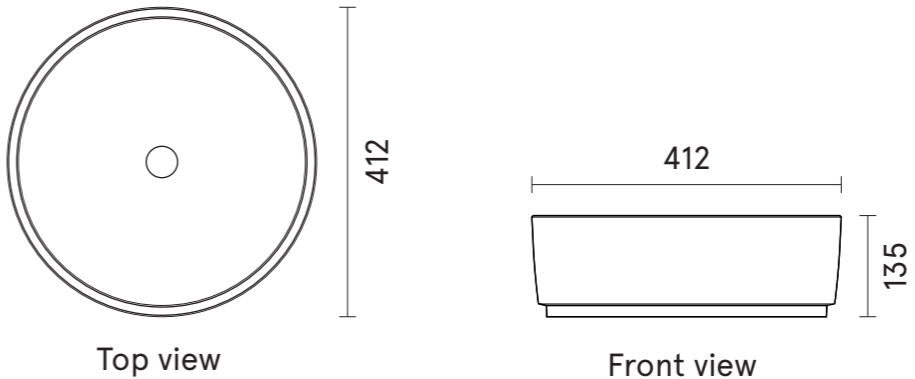



Fiore



Dimensions:

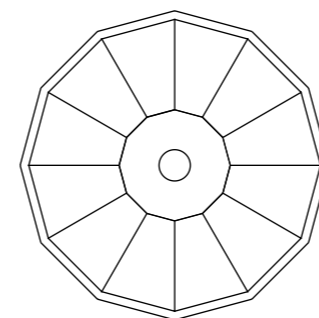

Top view

445

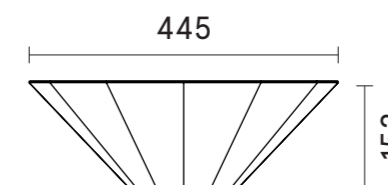

Front view

152



Artego



Dimensions:

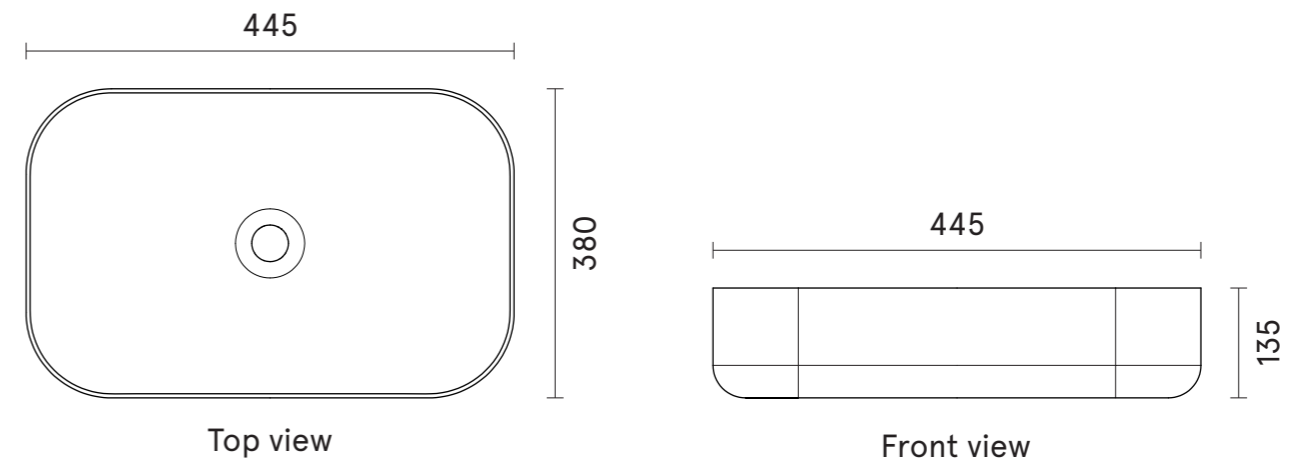

Monolith Series

Wash basins that suit you!

Customize various parameters of the wash basin to suit your space. The monolithic nature of the counter and the basin exhibits a unique sense of aesthetics.





Mono_CR



Dimensions:

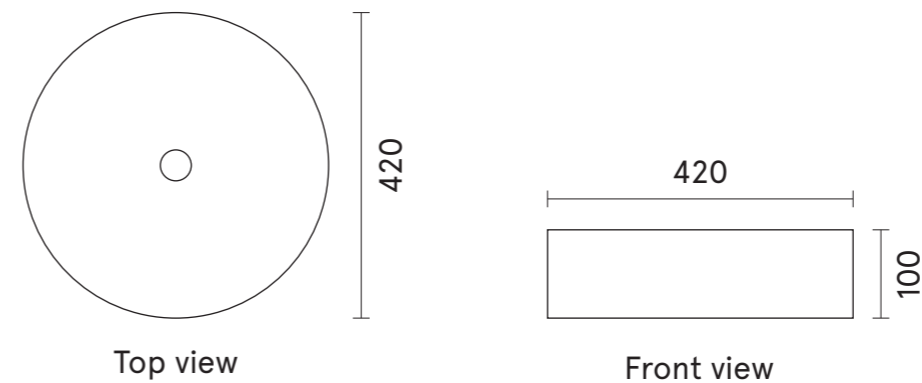



Mono_RT



Dimensions:

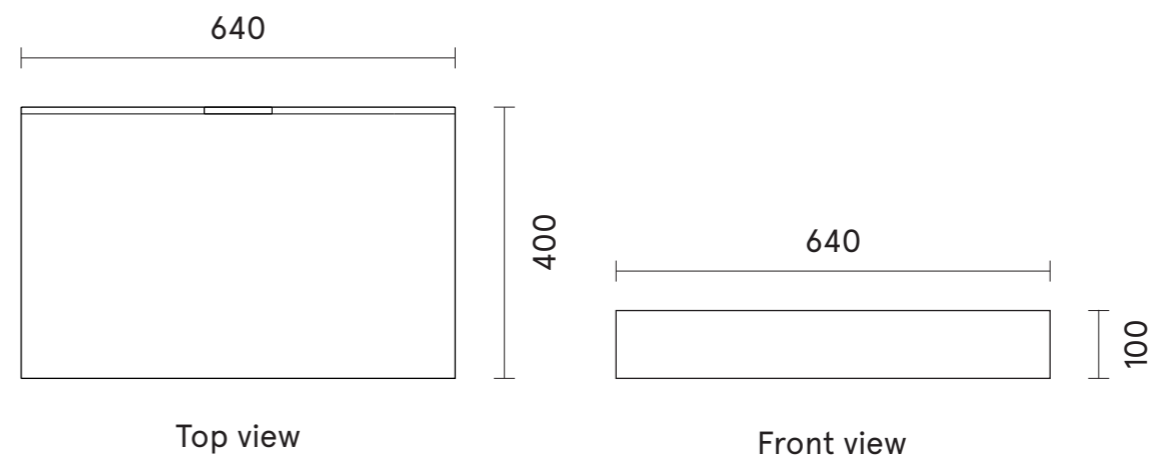



Mono_TR



Dimensions:

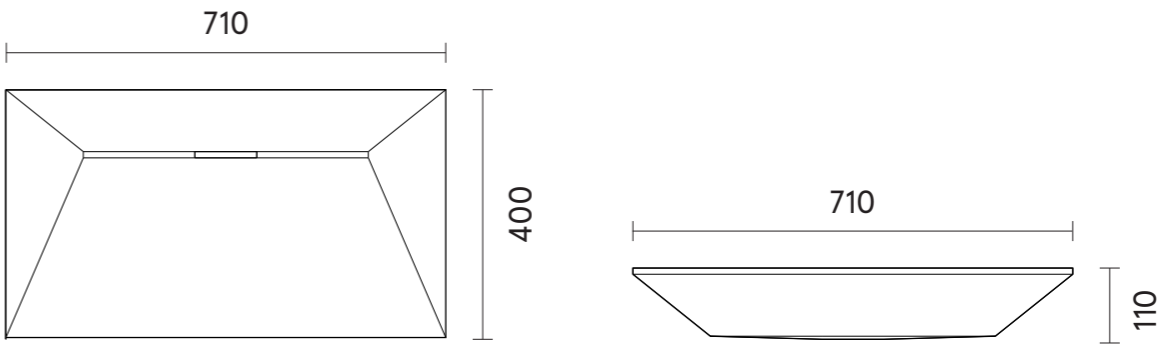

Top view

Front view



Halo_CR



Dimensions:

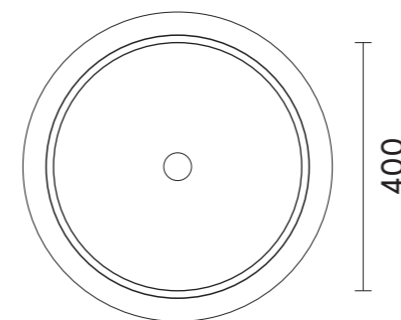

Top view

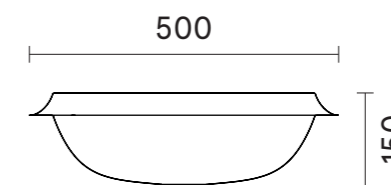

Front view



Halo_SQ



Dimensions:

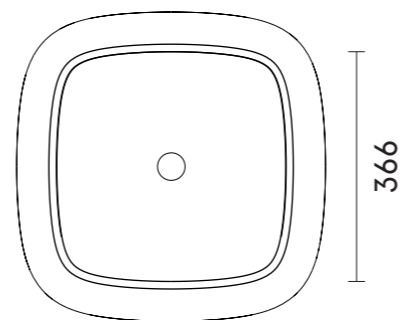

Top view

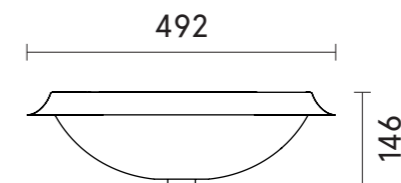

Front view

Specify Dimensions

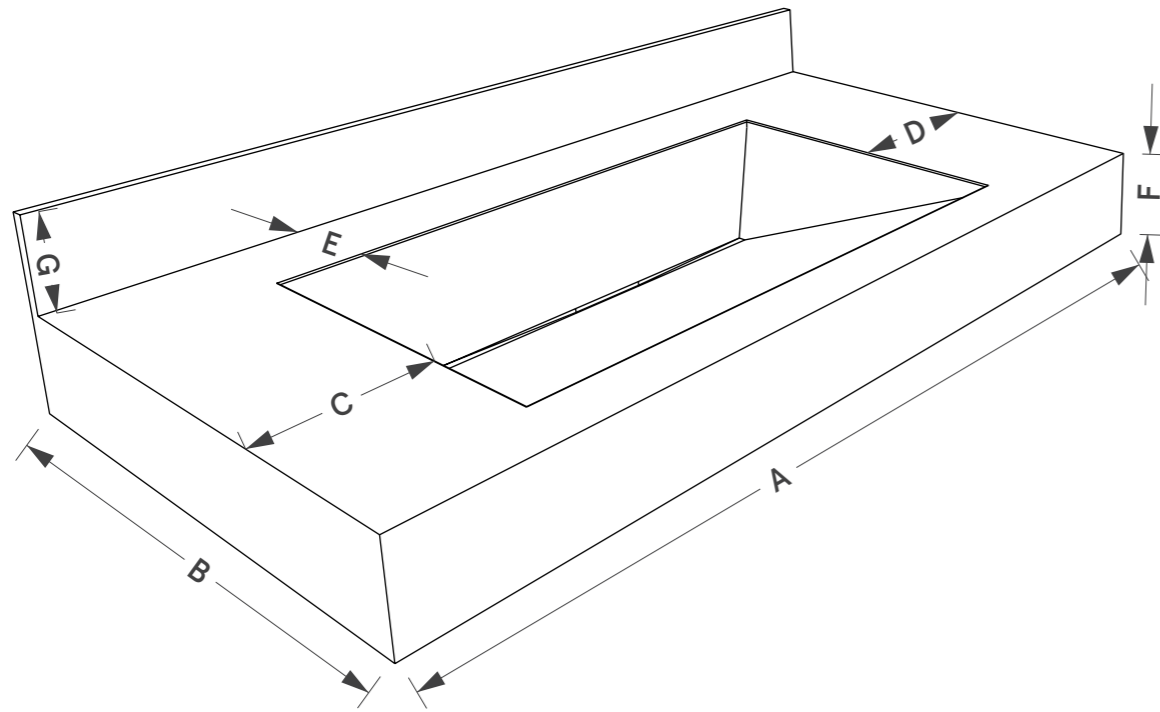

A - Length _____ mm

B - Depth _____ mm

C - Distance of basin from left sides _____ mm

D - Distance of basin from right sides _____ mm

E - Distance of basin from wall _____ mm

F - Fascia Height _____ mm

Number of fascia sides required _____ nos.

G - Height of Backsplash _____ mm

Care & Maintenance

- Do not place sharp objects directly on the surface.
- Spills and residues of food items such as citric juices, tea, turmeric, and toiletries such as soap, toothpaste, nail polish removers are to be wiped off/flushed off immediately.
- Do not use strong and acidic cleansers that are designed to remove stains in toilets and drains.
- Use only neutral cleaners and a soft sponge/cloth to wipe the surface.
- Do not clean the surface with solvents such as paint removers, xylene, paint thinners, etc. They will damage the surface treatment.
- Use of scouring agents and abrasive pads for scrubbing and cleaning the surface will damage the quality of the surface. It creates more damage to the surface rather than cleaning it.
- Using polish wax such as carnauba or paste wax will revive the surface and act a sacrificial layer.

*Litheoz being a hand crafted material, slight variations in color and microscopic cracks are a natural aspect of the material. Despite every effort to accurately match each product's color when we manufactured, actual color may vary. This is natural trait of concrete. The tonal difference complement its appearance.



Do not place sharp objects directly on the Surface



Do not place hot vessels directly on the Surface



Place hot objects on trivets



No acidic contact directly on the Surface



Use soft cloth or sponge to clean the surface

Kuance
STUDIO

www.thenuancestudio.com
info@thenuancestudio.com

