

ALTEZATM
ALUMINIUM WINDOW & DOOR SYSTEMS



APARNA-CRAFT EXTERIORS PVT LTD

Corporate Office: 8-2-293/82/A, 1214, Road No. 60
Jubilee Hills, Hyderabad - 500 033, Telangana, India
Tel.: +91 40 23606245 & 23357761 | Fax: +91 40 23606246
Helpline No.: +91 91211 65404 www.alteza.in
Email: info@alteza.in | Website: www.alteza.in
CIN: U28900TG2019PTC130572

ALTEZATM
ALUMINIUM WINDOW & DOOR SYSTEMS

BRING END-TO-END SOLUTIONS TO LIFE.

Passion. Precision. Performance.

Alteza premium aluminium window & door solutions offer customers a wide range of options in true high tech style contemporary designs with outstanding performance, security, ventilation, energy saving and deliver value for money.

Alteza's goal is to maximise the full benefits within the chosen aluminium profiles and achieve the position of a brand leader.

ALTEZA

Your Design. Your Solution. Your Choices.

Alteza directly works with individual architects and designers, meeting diverse needs and manufacturing window and door systems that fulfil specific requirements. To deliver outstanding quality and performance, Alteza initiates these one-on-one interactions right from the design phase itself. The advantages of this approach are many.

There is no deviation from specifications; customers enjoy enduring comfort, security and long-lasting satisfaction; and are doubly re-assured that every window and door system is individually manufactured to meet expectations.

These interactions are backed by an unrivalled approach to installation and customer service, completing the circle of the Alteza promise of an end-to-end solution.

At Alteza, your creative expression is set free and can be more attuned to the design needs than ever before. Each solution can be customised and made to meet your expectations, even exceed them.





Solutions Minus The Compromises

A question that is usually asked and left unanswered is, can there be anything better than unique technological innovations when it comes to windows and doors? Alteza believes there is the flexibility for architects and designers to configure innovations freely to meet specifications and individual requirements.

Alteza is way ahead in technology, enabling it to offer innovative window and door construction by drawing upon years of development, production and assembly expertise. Combining the best solutions and bringing about a perfect balance between the hardware and frame, profile and glazing, installation depth and insulation properties.

Alteza helps you take full advantage of the inherent strength of aluminium. A sturdy frame holds in-place very wide glass panes and easily support the original, high performing hardware fittings. Enabling you to specify and recommend really big windows and doors without undermining the strength of the slimmer looking framing system.



MADE WITH VIRGIN ALUMINIUM

All Alteza products are made using profiles made from virgin aluminium alloy 6063 - T6. This is the secret of building quality from inside-out. Aluminium is among the lightest engineering metals, and has a higher strength to weight ratio than steel when used as an alloy. The protective layer of aluminium oxide that forms on the surface makes it extremely resistant to corrosion from sea water, acid rain or anything that the weather can throw at it. To give your window a higher resistance to corrosion, Alteza offers anodising or powder coating the surface for an enduring and blemish-free finish.



Tall Windows & Taller Doors

Although Alteza aluminium window and door systems are available in all shapes and sizes, they can be created on a bespoke basis to suit your specific needs. The exclusive slimline customized aluminium windows and doors profiles enable you to have more glass. The beauty of this is, more glass allows more light to enter. The interior spaces are not only better lit but also look more spacious, plus give you a wider and better view.



LESS FRAME, MORE VIEW

Alteza makes one of the sleekest Aluminium windows & doors using slim profiles. These windows can be made very large and very wide, and yet stay thermally efficient. Uninterrupted views of surrounding landscapes, providing excellent air circulating capabilities and allowing natural sunlight to flood into the interiors at the touch of the button are some of the hard to match benefits. Alteza windows come with excellent security features designed to discourage break-ins.



FLUSH TO FLOOR THRESHOLD

Alteza aluminium windows and doors not only offer large glass panels, ensure smooth sliding, and provide slimmer sightlines, they also come with the very desirable window and door benefit of being able to move smoothly on tracks that are embedded into the floor flush. You have a threshold that is level with the floor. The low threshold also creates a fluid link between your indoors and outdoors. Everyone finds it easy to move around the house. Right from toddlers, the elderly in wheelchairs, babies in prams, kids on bikes, level thresholds make spaces not only look good but also provide smooth and easier access. Working closely with your architect and builder, Alteza ensures the opening is correctly built, tightly fitted and the correct drainage systems is put in place to prevent ingress of water during rains and thunderstorms.



Customization

Made to Order Customization means everything is looked at from your point of view and the product is tailored to your specific needs. Alteza offers customized aluminium windows and doors systems. Making total customization a reality in styles, in size, in glazing options and in colours. Alteza can give you what you want, not just what you need.

The Alteza Range of Window & Door Solutions

Looking for high quality windows and doors that won't let you down in the years to come? Want the security you need and are uncomplicated to use? Then Alteza is the right choice for you.

Whether it is a simple balcony window or door, large-surface tilt and turn window and door or the innovative lift and slide door. While they might differ in their individual opening types, their quality, engineering and workmanship is the same. They offer the perfect solution no matter what the dimension and will exceed your expectations.

Modern design and large-surface windows and doors blur the boundaries between your outdoors and your indoor living space. With an impressive price-performance ratio on your side, you can breathe easy and focus all your attention on creating new perspectives within your own four walls, and multiply the scope of living well.



Aluminium Window Types

Aluminium Fixed Window

Alteza aluminium fixed windows maximize natural light throughout the interior spaces. Combined with correct glass configuration, these windows perform high on noise reduction and energy efficiency. Customized through more glass and less frame, these windows offer beautiful sightlines with less hindrance.

Alteza aluminium fixed windows use virgin grade aluminium, ensuring that your windows are high on performance and built to last.

Features & Benefits

Alteza system used - ACA 47

- ☑ Thermally efficient
- ☑ Noise reduction
- ☑ Almost completely maintenance free
- ☑ Highly robust and durable
- ☑ Built to withstand heavy wind load pressure
- ☑ Customization in terms of size, glass, glazing and colour

Application: Residential and Commercial

Glass Configuration: 5mm Single glass to 28mm DGU

Window Styles:

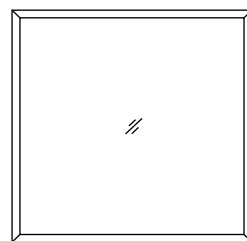

Aluminium Tilt and Turn Windows

Alteza tilt & turn window designs offer maximum security, energy efficiency and durability without compromising on style.

Tilt & turn windows offer unique dual opening mode as they operate on an advanced mechanism which enables them to operate on two axis'. These windows can be opened - as a standard casement windows operating on hinges screwed on one side and, - as tilted window which tilts slightly from upper side with base fixed, whenever air ventilation is needed without opening the entire window. This switch can be easily managed through moving the window handle in desired direction. Customization is also possible: glazing & glass options, robust hardware, choice of colours and sizes.

Features & Benefits

Alteza system used - ACA 47

- ☑ Allows maximum ventilation and easy cleaning
- ☑ Made using world-class technology
- ☑ Versatile and durable
- ☑ All surfaces are very finely smoothed and intricately finished
- ☑ Resilient to warping, corrosion and flexing
- ☑ Branded genuine glass & hardware
- ☑ Eco-friendly
- ☑ Up to 7ft high
- ☑ Can be done in combination
- ☑ Customization in terms of size, colour, glass, glazing and hardware

Application: Residential and Commercial

Glass Configuration: 5mm Single glass to 24mm DGU

Window Styles:

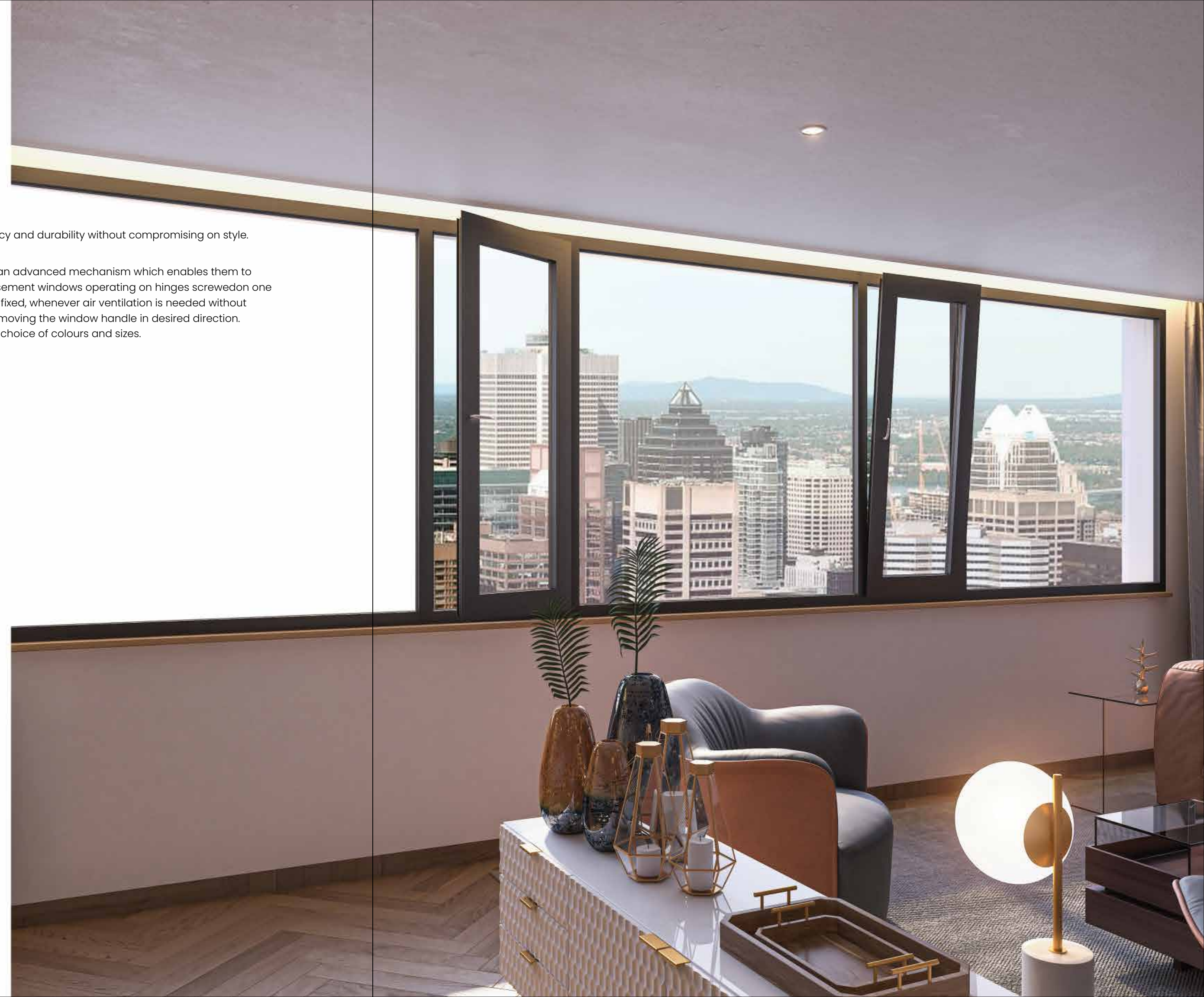
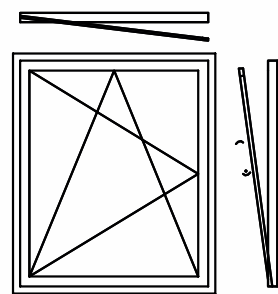

Aluminium Sliding windows

Alteza aluminium sliding window designs offer one of the most robust framed opening window system on the market.

Alteza aluminium sliding windows can be very large in size enabling uninterrupted views and suitable ventilation. Customization is possible: glazing & glass options, robust hardware, mesh, choice of colours and sizes. All Alteza Windows and doors are made of alloy 6063-T6, which is an architect alloy and is known for its strength, good surface finish and high corrosion resistance.

Features & Benefits

Alteza system used - ACA 27 / ACA 36

- ☒ Made using world-class technology
- ☒ Single and multipoint locking system
- ☒ Versatile and durable
- ☒ The horizontal sash movement ensures better ventilation
- ☒ Availability of multi-track systems
- ☒ Branded genuine glass & hardware
- ☒ Best utilization of space since the sashes open left to right or vice versa
- ☒ Built to withstand wind load pressure of up to 3.5 kpa
- ☒ Up to 6ft high
- ☒ Customization in terms of size, styles, glass, glazing, color and hardware

Application: Residential and Commercial

Glass Configuration: 5mm Single glass to 18mm DGU

Window Styles:

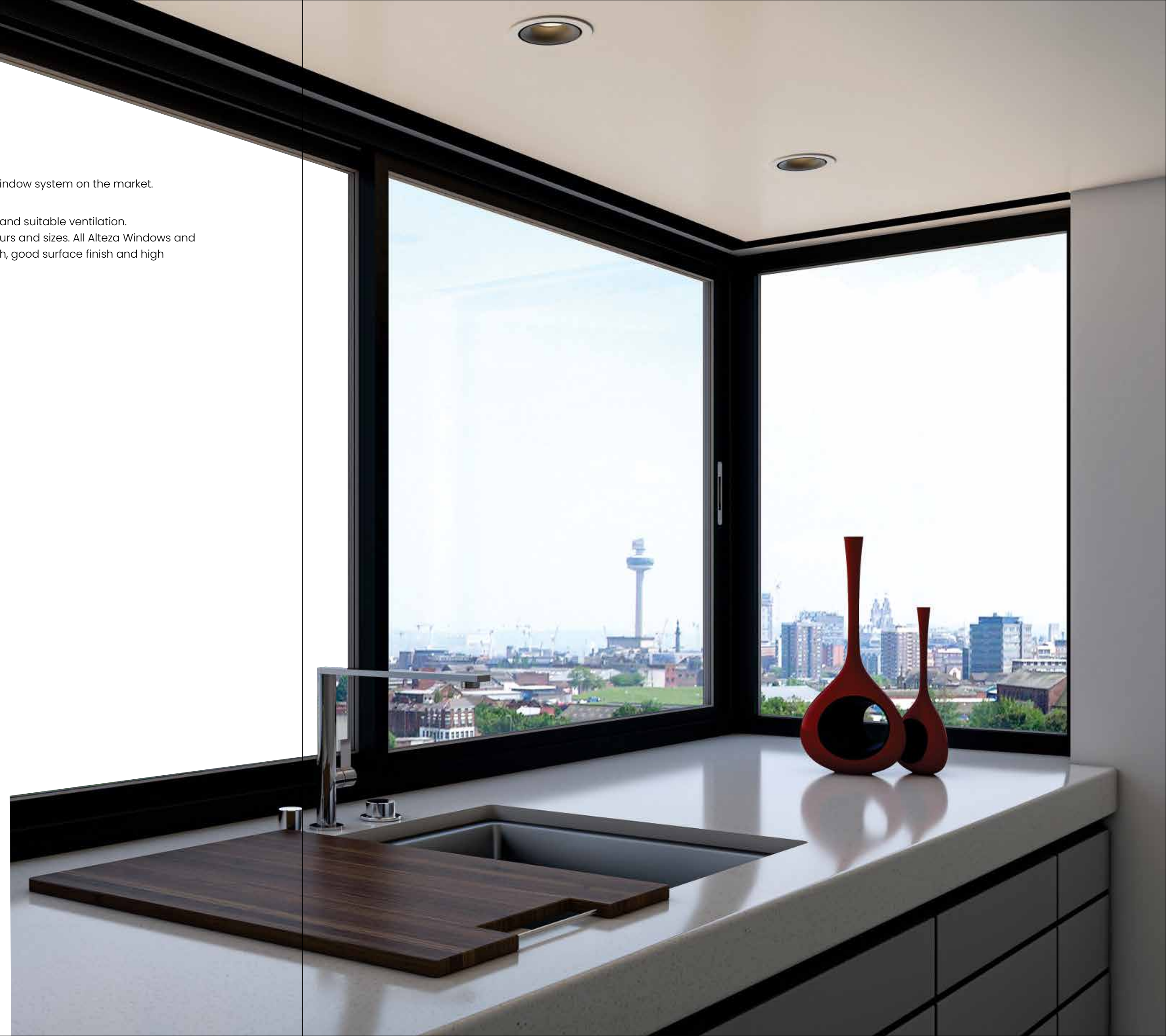
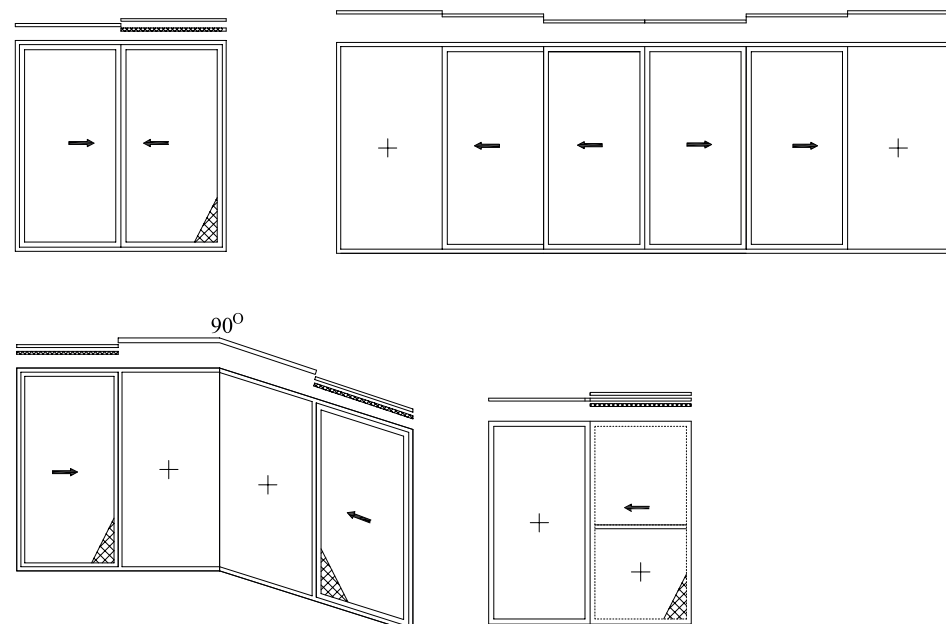

Aluminium Awning Windows

Alteza offers a comprehensive range of advanced aluminium ventilators to suit a wide variety of applications. All Alteza aluminium systems are tested to strict European and American standards.

Alteza extruded aluminium louver systems are designed for use in schools and higher education facilities, hospitals as well as a number of high profile residential and commercial structures. Alteza aluminium ventilators are manufactured to the bespoke sizes and colours required.

Features & Benefits

Alteza system used - ACA 47

- ☒ Automation possible for hardware systems
- ☒ World-class technology
- ☒ Highly durable
- ☒ Multiple design and locking options
- ☒ Wind load capacity of up to 3,5 KPA
- ☒ Eco friendly product
- ☒ Branded glass & hardware
- ☒ Customization in terms of size, glass and colour

Application: Residential and Commercial

Glass Configuration: 5mm Single glass to 28mm DGU

Window Styles:

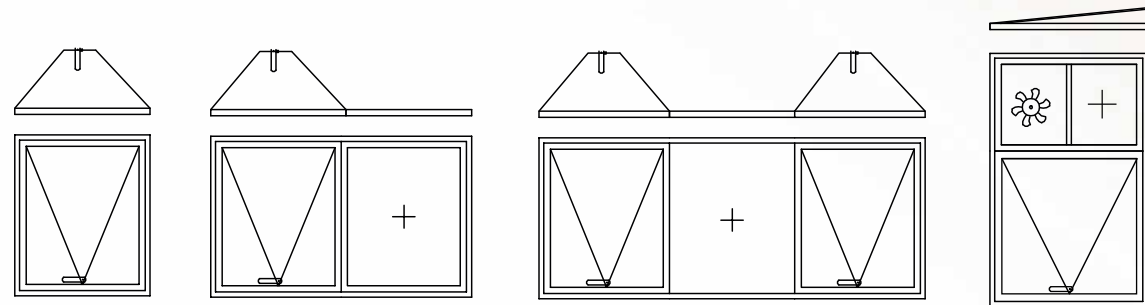

Aluminium Villa Window

The perfect combination of style and functionality, the aluminium villa windows design from Alteza are made using world-class technology and the highest quality of raw materials and workmanship. These sleek yet sturdy aluminium villa windows add a touch of elegance to your space while providing the benefits of reduced noise and better energy efficiency.

These villa windows come with a mesh/bug screen, safety grill and glass so that you can enjoy a well ventilated room while keeping away mosquitoes and flies.

Customize your villa windows with the glass, glazing, and colour of your choice and enjoy maximum ventilation.

Features & Benefits

Alteza system used - ACA 47

- ☑ Window with Glass, Mesh & Grill prefixed
- ☑ Made using world-class technology
- ☑ Goes up to 7 feet high
- ☑ Sturdy & secure
- ☑ Easy to maintain
- ☑ Branded European hardware
- ☑ Multi-point locking system for heightened security
- ☑ French openable window
- ☑ Customization in terms of size, glass, glazing and colour

Application: Residential and Commercial

Glass Configuration: 5mm Single glass to 28mm DGU

Window Styles:

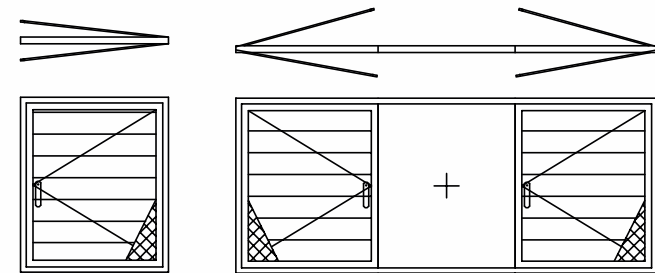

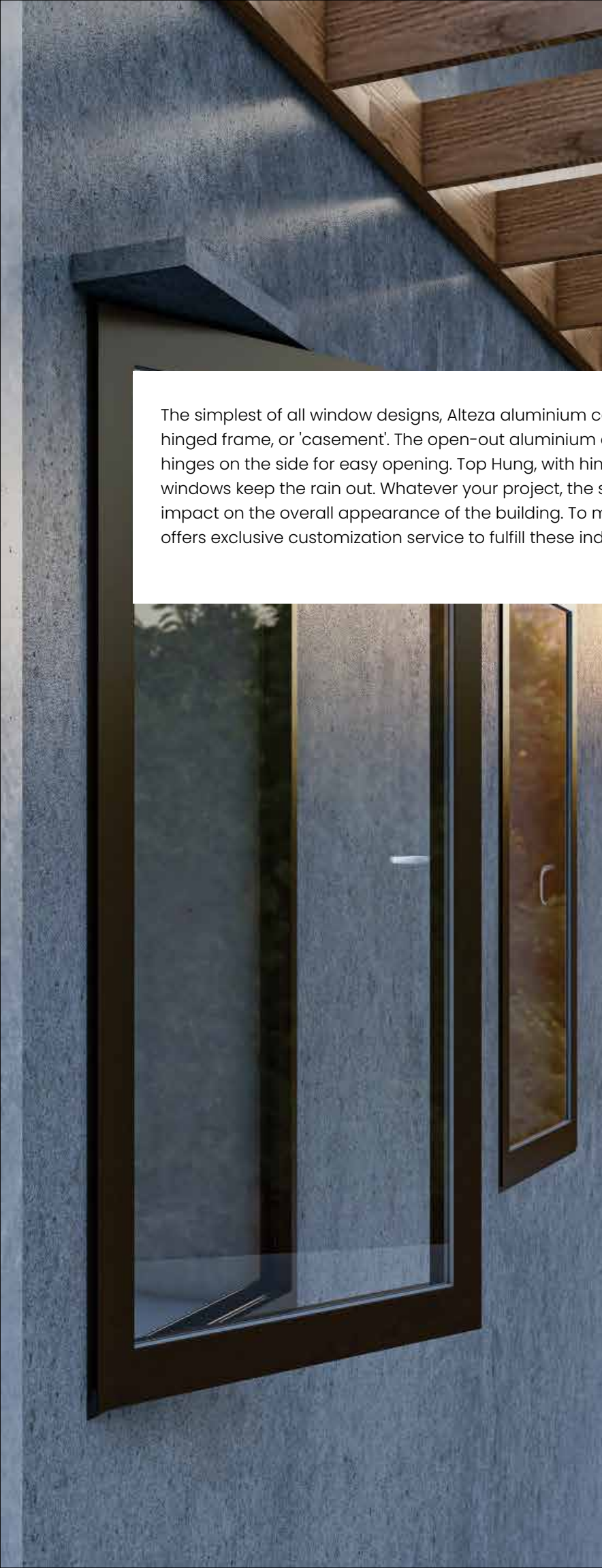

Aluminium Casement Windows

The simplest of all window designs, Alteza aluminium casement windows comprise a fixed, glazed frame and a second side hinged frame, or 'casement'. The open-out aluminium casement windows are available in a variety of formats – Side Hung with hinges on the side for easy opening. Top Hung, with hinges at the top, ideal for wet weather conditions as these casement windows keep the rain out. Whatever your project, the style of aluminium casement windows you choose will make a big impact on the overall appearance of the building. To meet your need for different shapes, sizes, and glazing options, Alteza offers exclusive customization service to fulfill these individual requirements.

Features & Benefits

Alteza system used – ACA 47

- ☑ Made using world class technology
- ☑ Multi-point locking for increased security
- ☑ Branded genuine glass & hardware
- ☑ Robust, durable and non-corroding
- ☑ Up to 6 ft high
- ☑ Customization in terms of size/ colour/ hardware

Application: Residential and Commercial

Glass Configuration: 5mm Single glass to 28mm DGU

Window Styles:

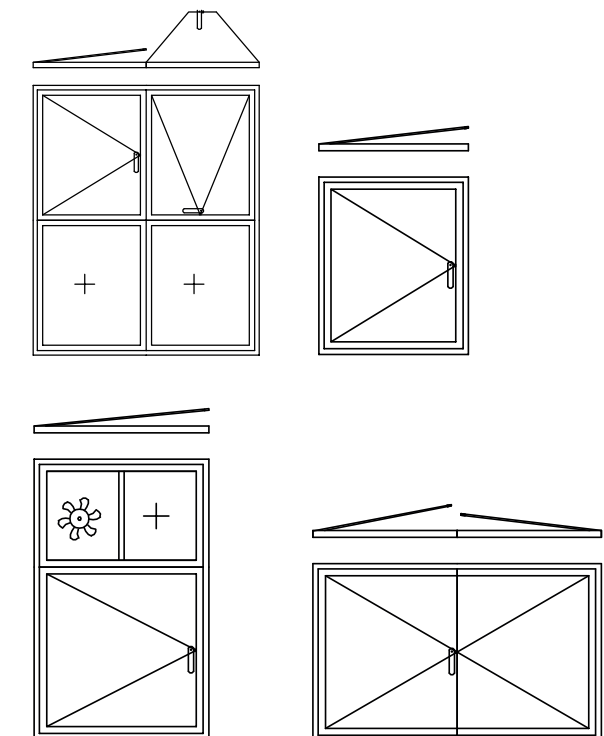

Sliding window with integrated railing

Nothing is appreciated more by Architects and Designers than a very slim framed window that fits in with their design scheme.

These windows are ideal solutions for high rise buildings with no balconies. To increase their safety, 2.5 feet height from floor is also fixed. While a door slides on the tracks, only a window size opening is available to let the fresh air enter the space.

Features & Benefits

Alteza system used - ACA 36

- ☒ Made using world-class technology
- ☒ Versatile and durable
- ☒ The horizontal sash movement ensures better ventilation
- ☒ Branded genuine glass & hardware
- ☒ Best utilization of space since the sashes open left to right or vice versa
- ☒ Built to withstand wind load pressure of up to 3.5 KPA
- ☒ Up to 9 ft high
- ☒ Customization in terms of size, styles, glass, glazing, color and hardware

Application: Residential and Commercial

Glass Configuration: 5mm Single glass to 24mm DGU

Window Styles:

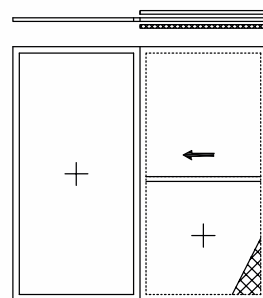

Aluminium Door Types

Aluminium Casement Doors

Alteza aluminium casement doors are ideal additions to commercial or larger residential projects due to their durability, high levels of performance and low maintenance. Our casement doors can either have fixed panels or can come attached to the frame with one or more hinges, typically allowing them to open to the side. Customization is possible: glazing & glass options, robust hardware, mesh, choice of colours and sizes.

Features & Benefits

Alteza system used - ACA 47

- ☒ Comes with multi-locking system for enhanced security
- ☒ All surfaces are very finely smoothed and intricately finished
- ☒ Robust, durable and non-corroding
- ☒ Resilient to warping, corrosion and flexing
- ☒ Up to 10 feet tall
- ☒ Branded genuine glass & hardware
- ☒ Option to add 3-D hinges for smooth movement
- ☒ Customization in terms of size/ colour/ hardware
- ☒ 4 threshold options available - 0 mm, 8 mm, 22mm & 47 mm
- ☒ Can accommodate door closure systems
- ☒ Customized opening possible - Inward or outward
- ☒ Both pivot & side hung mechanisms available

Application: Residential and Commercial

Glass Configuration: 5mm Single glass to 28mm DGU

Door Styles:

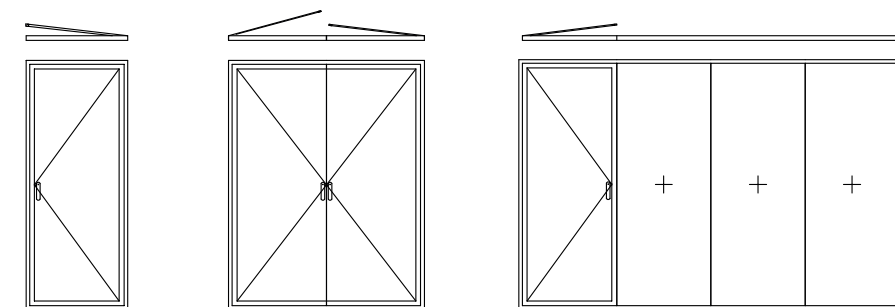

Aluminium Slide and Fold Doors

This is the next generation solution in aluminium slide and fold door systems. These high performance aluminium folding door systems facilitate wider opening to the given space. Even with a dramatic reduction in framing size, Alteza maintains its high thermal performance and insulation. Every Alteza aluminium slide and fold door is fully tested for performance and long life. Customization is possible: glazing & glass options, robust hardware, choice of colours and sizes.

Features & Benefits

Alteza system used - ACA SF

- ☑ Made using world-class technology
- ☑ Versatile and durable
- ☑ All surfaces are very finely smoothed and intricately finished
- ☑ Highly robust, durable and weather-proof
- ☑ Resilient to warping, corrosion and flexing
- ☑ Thermally efficient
- ☑ Noise reduction
- ☑ Up to 8 feet tall
- ☑ Smooth and easy to operate
- ☑ Branded genuine glass & hardware
- ☑ Customization in terms of size & colours

Application: Residential and Commercial

Glass Configuration: 8mm Single glass or 24mm DGU

Door Styles:

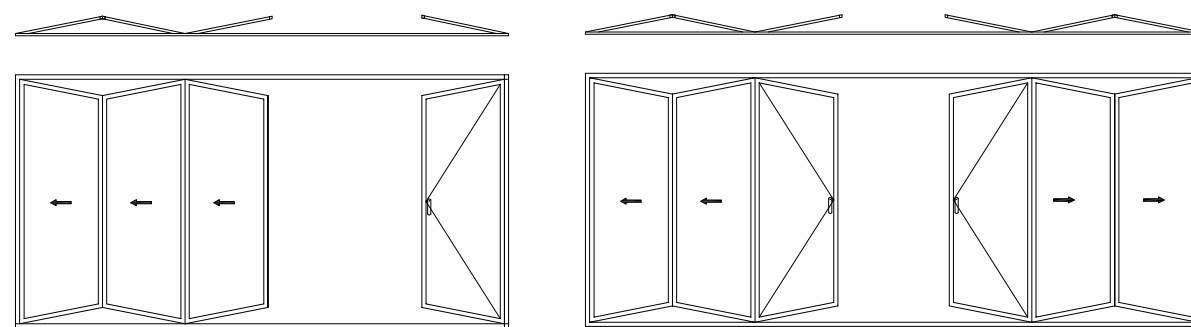

Aluminium Lift and Slide Doors

Alteza lift and slide aluminium doors combine exceptional design with optimal performance. Removing the burden of exertion when you want to open these doors to let the outside air. The sliding panel of the door operates on its own track, so no additional space is required outside or inside your home. Just turn the door handle 180° to raise the door on its tracks, reduce friction and it just glides open or close, the sliding is smooth and effortless. Customization is possible: glazing & glass options, robust hardware, choice of colours and sizes

Features & Benefits

Alteza system used - ACA LS

- ☑ Versatile and durable
- ☑ Resilient to warping, corrosion and flexing
- ☑ Provides thermal and noise insulation
- ☑ 100% recyclable
- ☑ Up to 10 feet tall
- ☑ Branded genuine glass & European hardware
- ☑ Customization in terms of size, glass and color

Application: Residential and Commercial

Glass Configuration: 24mm Single glass to 30mm DGU

Door Styles:

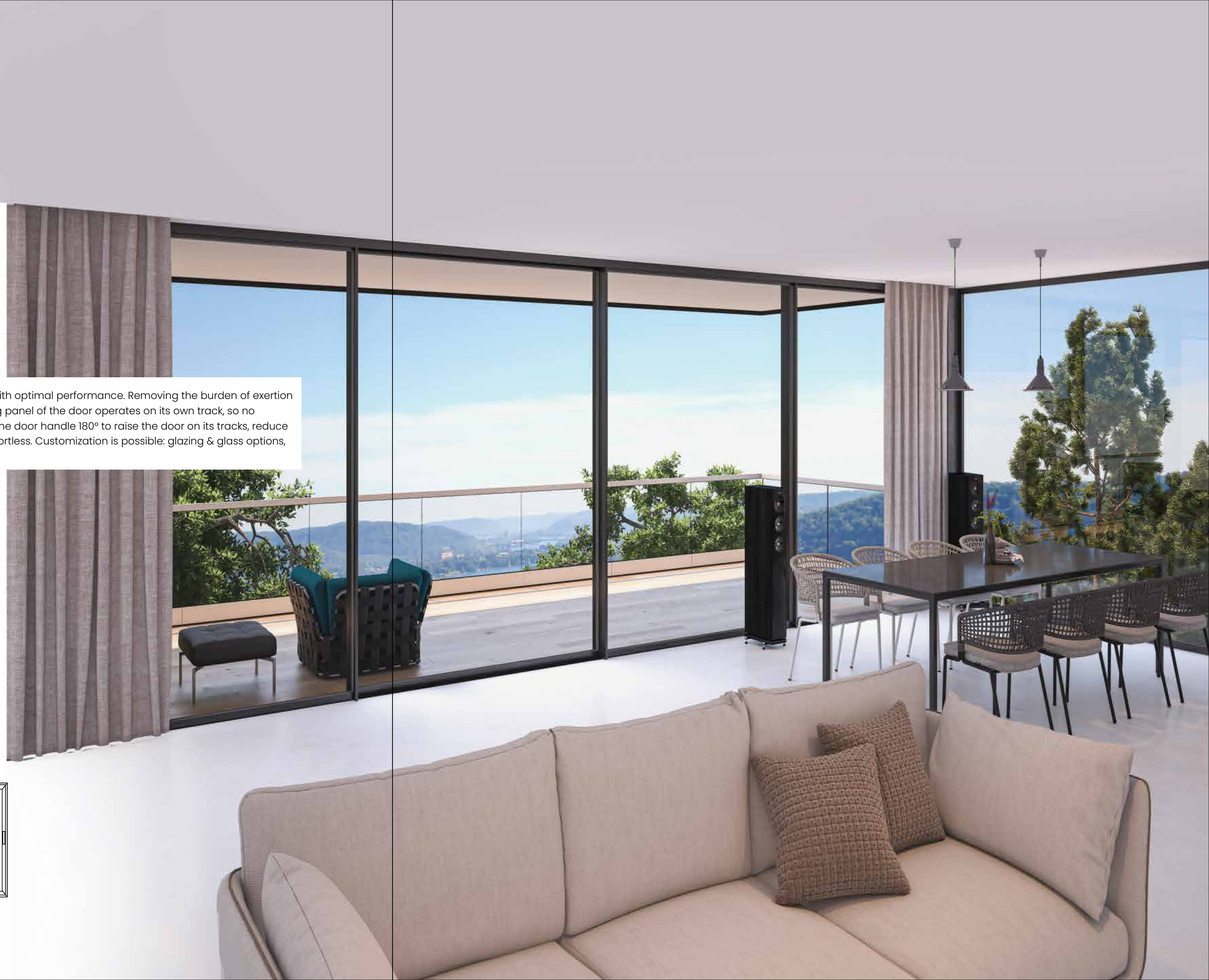
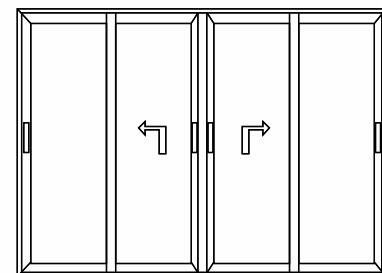
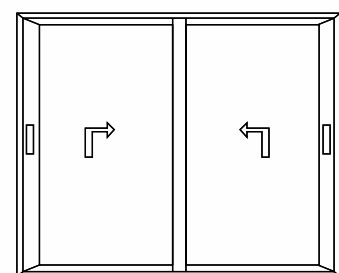

Aluminium Sliding Doors

Alteza aluminium sliding door design offers flexibility, where one panel can move while the other stays static. You could also have both panels of the door slide independent of each other. These sliding doors offer wide, uninterrupted views and save space as they won't encroach on your balcony or interiors of a home. The sliding doors move on 2.5 or 3.5 tracks. Customization is possible: glazing & glass options, robust hardware, mesh, choice of colours and sizes.

Features & Benefits

Alteza system used - ACA 36

- ☑ Versatile and durable
- ☑ Precision rollers ensure smooth movement
- ☑ Option to add mesh track
- ☑ Highly durable and can withstand extreme temperatures
- ☑ Built to withstand wind load pressure of up to 3.5 kpa
- ☑ Eco-friendly
- ☑ Up to 9 ft
- ☑ Almost completely maintenance free
- ☑ Branded genuine glass & hardware
- ☑ Customization in terms of size, glass and colour

Application: Residential and Commercial

Glass Configuration: 5mm Single glass to 24mm DGU

Door Styles:

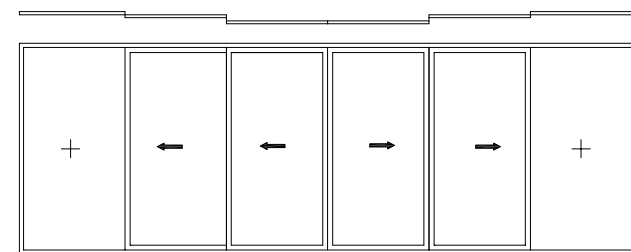
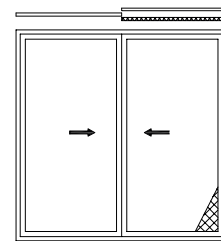



Corner opening / Pocket Opening

Open corner is an ultimate indoor/outdoor living space solution. Opening up the entire corner of the living space with the sliding Door meeting at the corner.

These specially designed corner window solutions do not compromise on the strength or the security they can provide. They add an incredible architectural feature to your building that is truly unique. Let you offer residents a spectacular and panoramic view of the landscape surrounding the building.

Features & Benefits

Alteza system used - ACA M 19

- ☒ Maximum door dimension – 6.75 M²
- ☒ Precise 19 mm sightlines throughout the opening
- ☒ Unitized door system - Structurally bonded glass into the sash frame
- ☒ Precise corner opening – 90 degree sliding door possible
- ☒ Dedicated water track for rain water drainage
- ☒ Ideal for pocket openings
- ☒ Multi-point locking system
- ☒ Branded original hardware
- ☒ Customization in terms of colour, glass and glazing

Application: Residential and Commercial

Glass Configuration: 24 to 32 mm DGU

Door Styles:

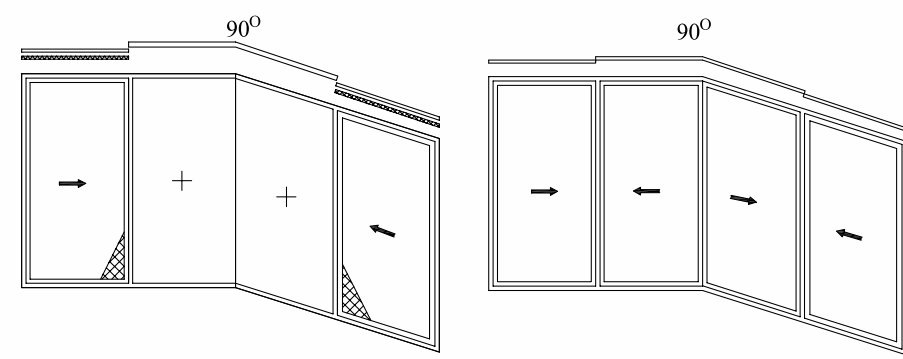

Aluminium slimline sliding doors

Ultra-slim sliding door is the latest and most advanced system in our product range, combining aesthetic beauty with everyday practicality. If you want large panels of glass with minimal sight lines of just 19 mm, high security and extreme weather rating, then this is it.

Choose from a wide range of configurations, bespoke sizes and a vast palette of colours, Alteza Slimline ACA M19 sliding door system can be tailored to suit the most demanding project. All the trickle vents are incorporated neatly through the outer frame head-track and colour-matched.

The advanced aluminium frame reduces the intermediate sight lines to just 19 mm - an amazingly slim sight line for sliding doors, which results in an incredible contemporary look. The sleek frame profile fits close to the glass, maintaining a truly slim sight line no matter the angle you view.

Features & Benefits

Alteza system used - ACA M 19

- ☑ Maximum door dimension - 6.75 M²
- ☑ Precise 19 mm sightlines throughout the opening
- ☑ Flush to floor/zero threshold - the bottom section of profile can go completely inside the floor to facilitate wheelchair movement
- ☑ Unitized door system - Structurally bonded glass into the sash frame
- ☑ Precise corner opening - 90 degree sliding door possible
- ☑ Dedicated water track for rain water drainage
- ☑ Ideal for pocket openings
- ☑ Multi-point locking system
- ☑ Branded original hardware
- ☑ Customization in terms of colour, glass and glazing

Application: Residential and Commercial

Glass Configuration: 24 to 32 mm DGU

Door Styles:

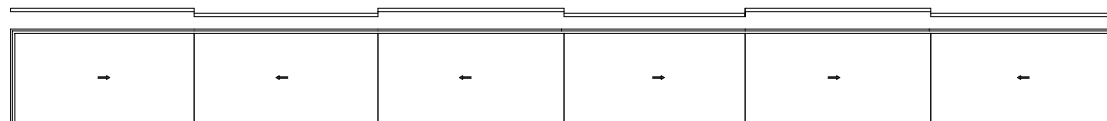
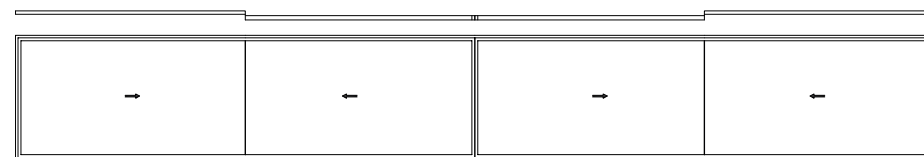
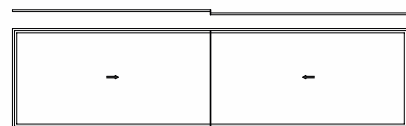

Aluminium Railings

Alteza breaks the mold by taking you away from heavy steel and introduces you to the modern, lightweight aluminium. Alteza products like aluminium glass railings add a whole new look that is modern, stylish, fresher and stronger than steel, yet remains very cost-effective at the same time. The main advantage however is the fact that aluminium never rusts or corrode and the installation requires the least maintenance. Ideal for balconies, Alteza aluminium railings can be tailored to suit your needs. The aluminium railings can be anodized or powder painted in the colour of your choice and the glazing and glass can be customized too.

Features & Benefits

- ☑ Made using world-class technology
- ☑ Highly durable
- ☑ Eco-friendly
- ☑ Branded tempered and laminate glass
- ☑ Frameless or standalone railings
- ☑ Customization in terms of size, glass and colour
- ☑ Floor mounted, wall mounted & concealed

Application: Residential and Commercial

Glass Configuration: Single or Laminated Glazing

Railing Styles:

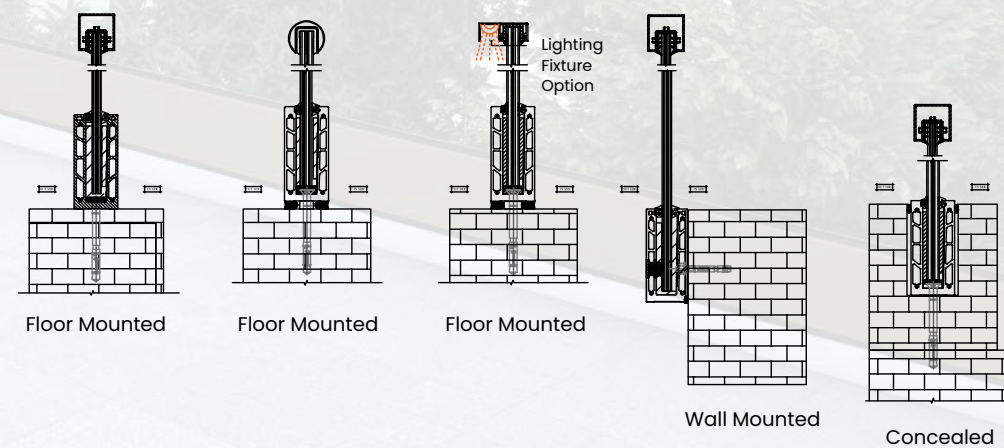

ACA 47

Glazing min 5mm
single glass to max
24mm DGU

Single and multiple
locking system with
variety of handles

Best sound insulation
due to center gasket
& DGU glass, noise
reduction up to 30db

Branded Hardware
with 5years
warranty

Possible Max Size
1000mm X 3000mm

Frame width & height
47mm for windows

Center stile gasket
for better air and
water tightness



Technical Specifications

Basic System depth (mm) - 47

Maximum infill glass thickness (mm) - 26

Minimum visible side (mm) - 47

Minimum sash depth (mm) - 47

Maximum sash weight (kg) - 180

System height (mm) - 47

Maximum shutter area (Sq Mt.) - 2.7



ACA 27



Glazing min 5mm
single glass to max
18mm DGU

Single and multiple
locking system with
variety of handles
and key lock option

Slim interlock of
40mm

Branded Hardware
with 5years
warranty

Design drainage
slope for better
water penetration

System USP is its
inbuilt railing system

Max Size 1500mm X
2100mm

Profile thickness
1.2mm to 2mm

2.5 / 3.5 track with
SS or fiber mosquito
mesh

Europeon standards
with detachable rail

Technical Specifications

Basic System Depth - 2.5 track (mm) - 81

Basic System Depth - 3.5 track (mm) - 115

Maximum infill glass thickness (mm) - 18

Minimum visible side (mm) - 105

Minimum visible Interlock (mm) - 40

Minimum sash depth (mm) - 27

Maximum sash weight (kg) - 160

System height (mm) - 46

Maximum shutter height (mm) - 2150

Maximum shutter width (mm) - 1500

Maximum shutter area (Sq Mt.) - 3.15



ACA 36



Glazing min 5mm
single glass to max
18mm DGU

Single and multiple
locking system with
variety of handles
and key lock option

Slim interlock of
40mm

Branded Hardware
with 5years
warranty

Design drainage
slope for better
water penetration

System USP is its
inbuilt railing system

Reinforcement
Interlock for higher
wind pressure

Max Size
1500mm X 2800mm

2.5 / 3.5 track with
SS or fiber
mosquito mesh

Europeon standards
with
detachable rail

Technical Specifications

Basic System Depth - 2.5 track (mm) - 100

Basic System Depth - 3.5 track (mm) - 142

Maximum infill glass thickness (mm) - 28

Minimum visible side (mm) - 110

Minimum visible Interlock (mm) - 40

Minimum sash depth (mm) - 36

Maximum sash weight (kg) - 200

System height (mm) - 46

Maximum shutter height (mm) - 2800

Maximum shutter width (mm) - 1500

Maximum shutter area (Sq Mt.) - 4.2

ACA SLIM LINE - M 19

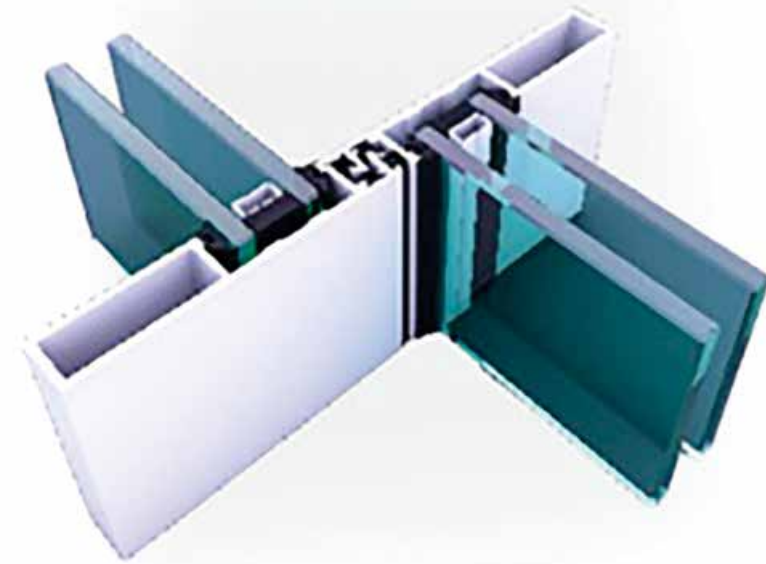

Glazing min 24mm
32mm DGU

Multipoint locking
system with variety
of handles and key
lock options

Slim interlock of
19mm

Branded Hardware
with 5 years of
warranty

System can
concealed to floor,
wheel chair
accessible

System USP is
maximum view with
minimum aluminium
Visibility

Max size of single
shutter 1500mm X
4500mm

Profile thickness best
in class 2mm to
3.5mm

2 track with corner
opening typology is
possible

Water penetration
up to 600pa with
extra gutter system

Technical Specifications

Basic System Depth - 2 track (mm) - 140

Maximum infill glass thickness (mm) - 31

Minimum visible side (mm) - 45

Minimum visible Interlock (mm) - 19

Minimum sash depth (mm) - 97

Maximum sash weight (kg) - 300

System height (mm) - 45

Maximum shutter height (mm) - 4500

Maximum shutter width (mm) - 2100

Maximum shutter area (Sq Mt.) - 6.75



ACA LIFT & SLIDE



Glazing min 24mm to 32mm DGU

Minimum threshold of 22mm

Multiple locking system with variety of handles and key lock option

European Hardware with 5years warranty

System USP is big & heavy shutters with easy movements

Max Size 1800mm X 2400mm

Profile thickness beat in class 2mm to 3.5mm

Any points locking shutter

Technical Specifications

Basic System Depth - 2.5 track (mm) - 135

Maximum infill glass thickness (mm) - 24

Minimum visible side (mm) - 117

Minimum visible Interlock (mm) - 70

Minimum sash depth (mm) - 50

Maximum sash weight (kg) - 200

System height (mm) - 46

Maximum shutter height (mm) - 3000

Maximum shutter width (mm) - 1800

Maximum shutter area (Sq Mt.) - 5.4



ACA SLIDE & FOLD



Glazing min 8mm single glass or 24mm DGU	Minimum threshold of 44mm	Multiple locking system
European Hardware with 5years warranty	Best air and water tightness because of folding point gasket	Odd shutter combination 1 openable 3/5/7 sliding
Max Size 1000mm X 2400mm	Profile thickness 2mm to 5mm	Maximum opening easy to operate
Inside or outside opening is possible	Bottom roller system for better performance	

Technical Specifications

- Basic System depth - 75
- Maximum infill glass thickness (mm) - 24
- Minimum visible side (mm) - 114
- Minimum visible Interlock (mm) - 154
- Minimum sash depth (mm) - 75
- Maximum sash weight (kg) - 100
- Maximum shutter height (mm) - 2400
- Maximum shutter width (mm) - 1000
- Maximum shutter area (Sq Mt.) - 2.4

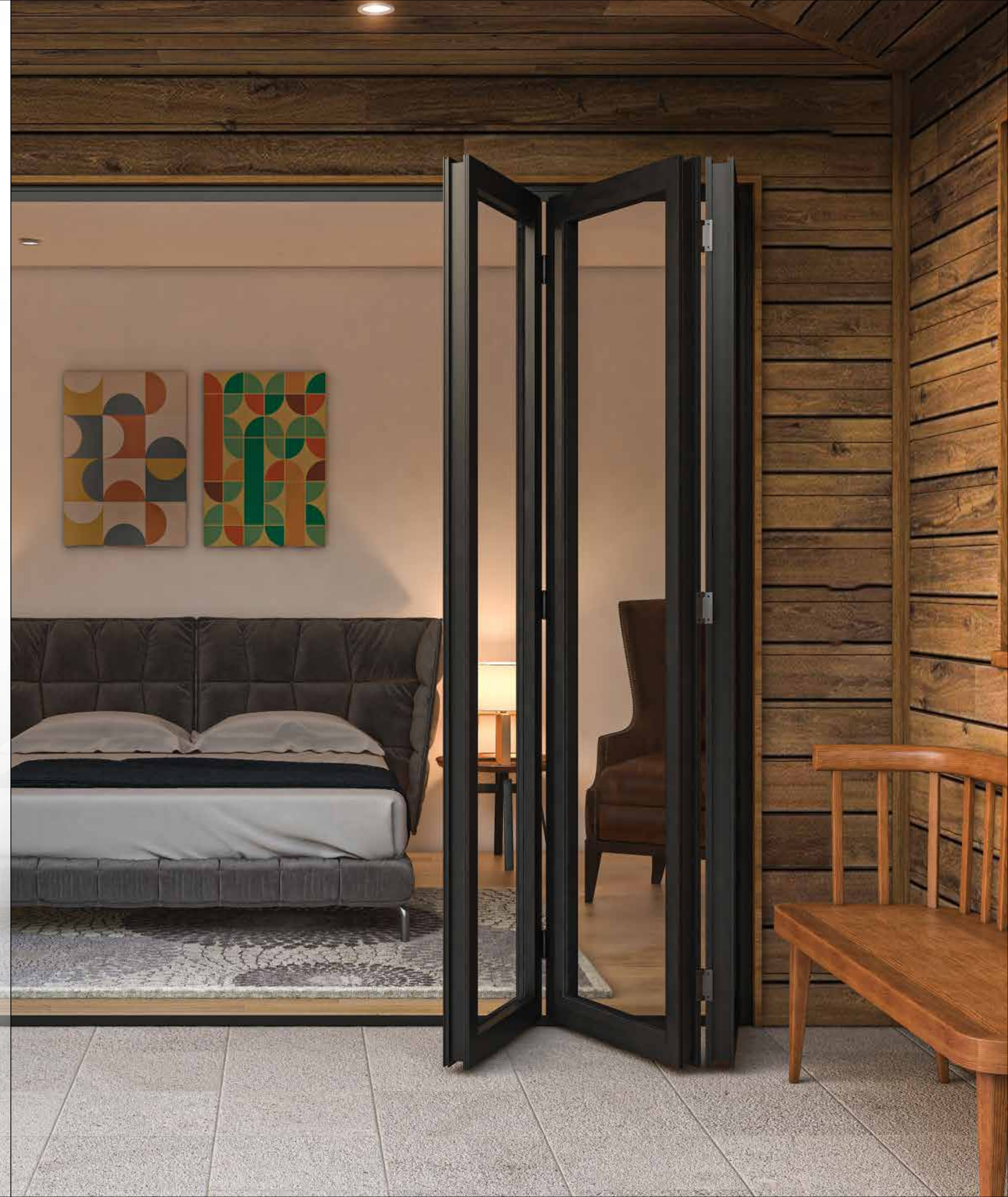

ALTEZA SYSTEMS	ACA 47	ACA 27	ACA 36	ACA LS	ACA SF	ACA M 19	ACA GR
----------------	--------	--------	--------	--------	--------	----------	--------

DOOR

Casement Door	✓						
Combination Door	✓	✓	✓				
Sliding 2 Track Door				✓		✓	
Sliding 2.5 Track Door		✓	✓				
Sliding 3.5 Track Door		✓	✓				
Slide & Fold Door					✓		
Lift and Slide Door				✓			
Corner door (90 degree sliding)						✓	

WINDOW

Fixed Window	✓						
Casement Window	✓						
Awning window	✓						
Tilt and Turn Window	✓						
Combination window	✓	✓	✓				
Sliding 2.5 track window		✓	✓	✓			
Sliding 3.5 track window		✓	✓				
Villa Window	✓						
Lift and Slide Window				✓			
Sliding window with Integrated Railing		✓	✓				

VENTILATORS

Fixed with exhaust fan	✓						
Fixed with Louvers	✓						

RAILING

Glass Railing							✓
---------------	--	--	--	--	--	--	---

	ACA 47	Villa window	ACA 27	ACA 36	ACA LS	ACA SF	ACA GR	ACA M 19
Basic System depth	47	115				75	60	
Basic System Depth - 2.5 track (mm)			81	100	135			140
Basic System Depth - 3.5 track (mm)			115	142				
Maximum infill glass thickness (mm)	26	24	18	28	24	24	17.52	31
Minimum bottom bracket height (mm)							130	
Minimum visible side (mm)	47	110	105	110	117	114		45
Minimum visible Interlock (mm)			40	40	70	154		19
Hand rail width (mm)							25	
Minimum sash depth (mm)	47	47	27	36	50	75		97
Maximum sash weight (kg)	180	100	160	200	200	100		300
System height (mm)	47	24	46	46				45
Maximum shutter height (mm)	3000	1800	2150	2800	3000	2400		4500
Maximum shutter width (mm)	1000	1000	1500	1500	1800	1000		2100
Maximum shutter area (Sq Mt.)	2.7	1.8	3.15	4.2	5.4	2.4		6.75

Typologies Casement



Typologies Sliding

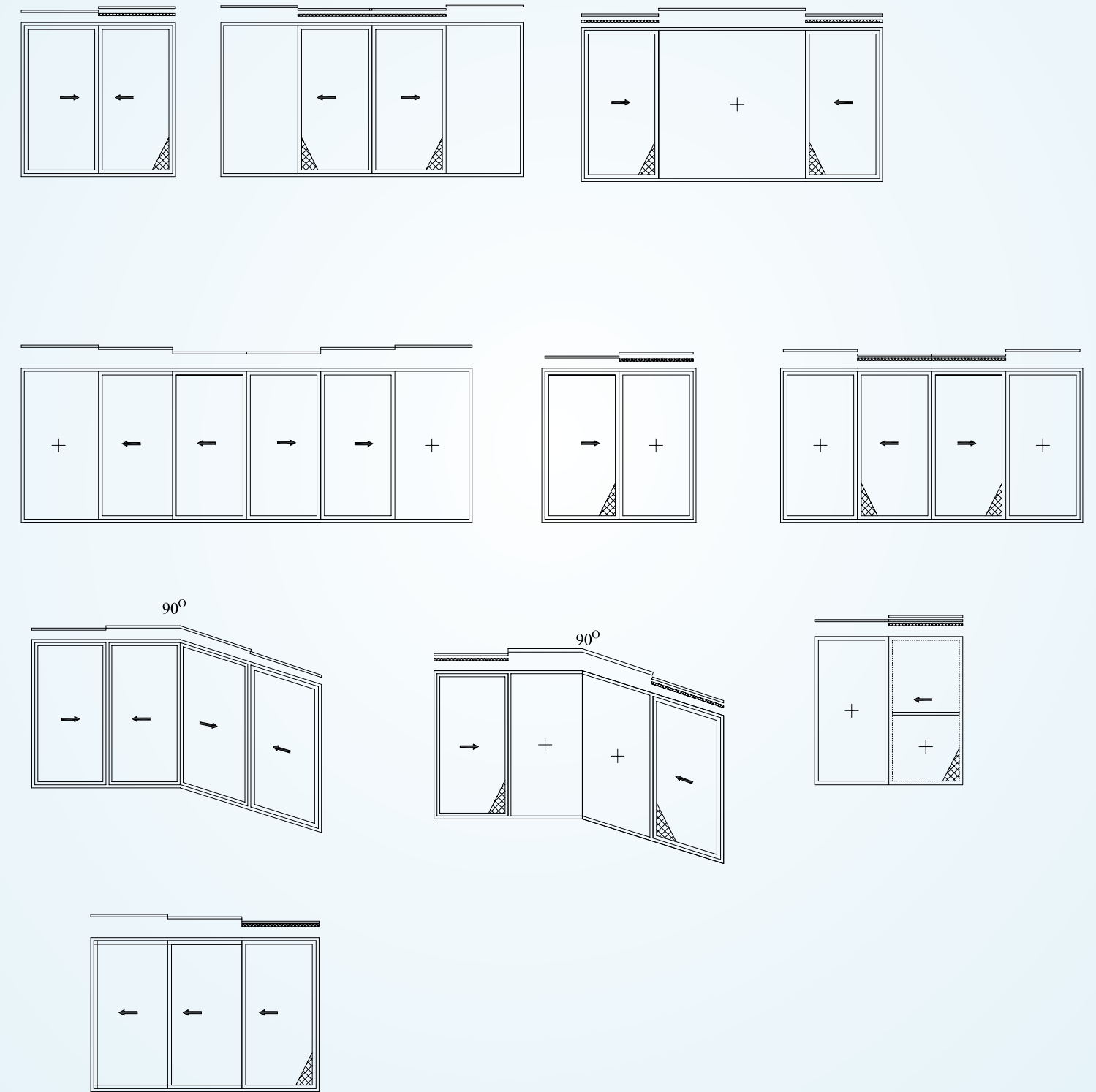

Slimline Series

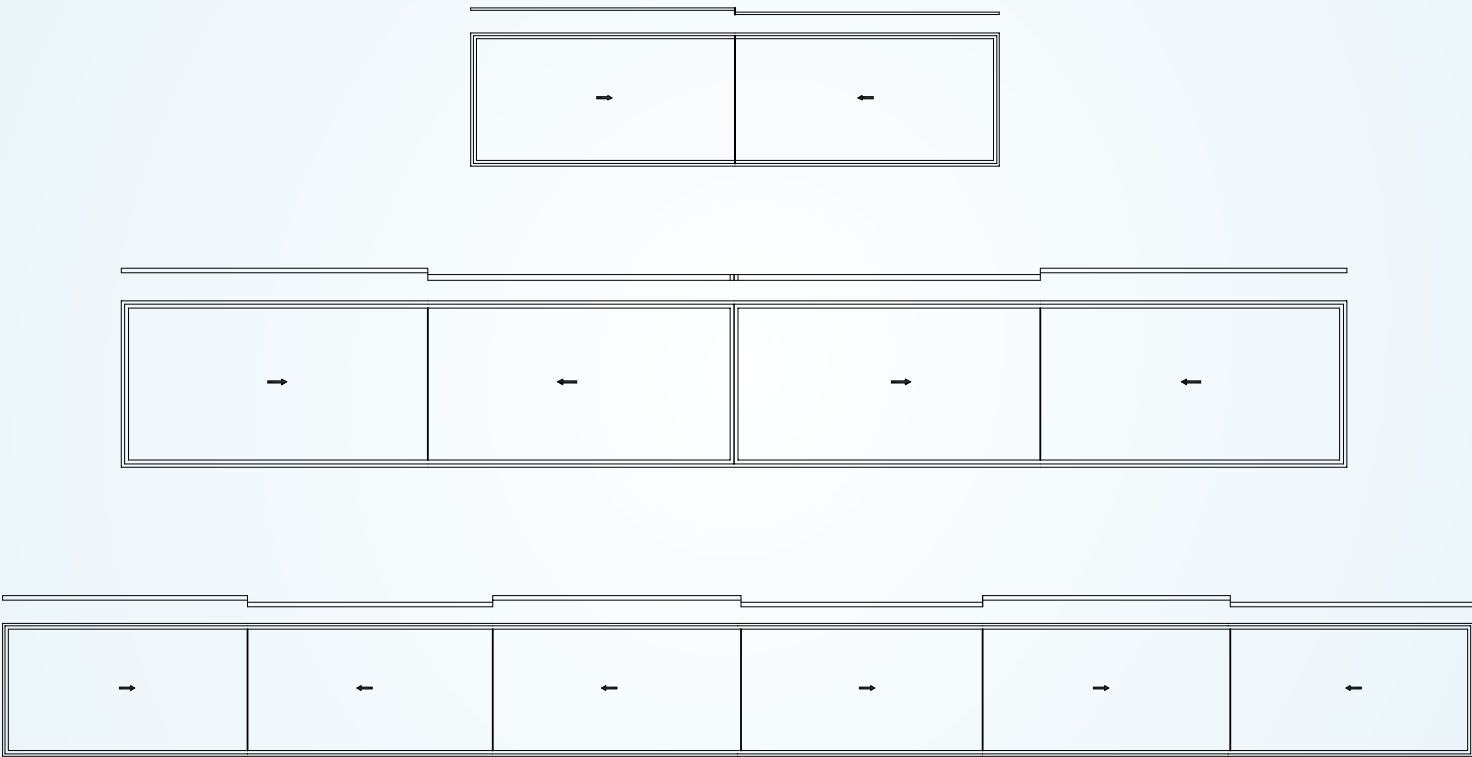

Hand Railing

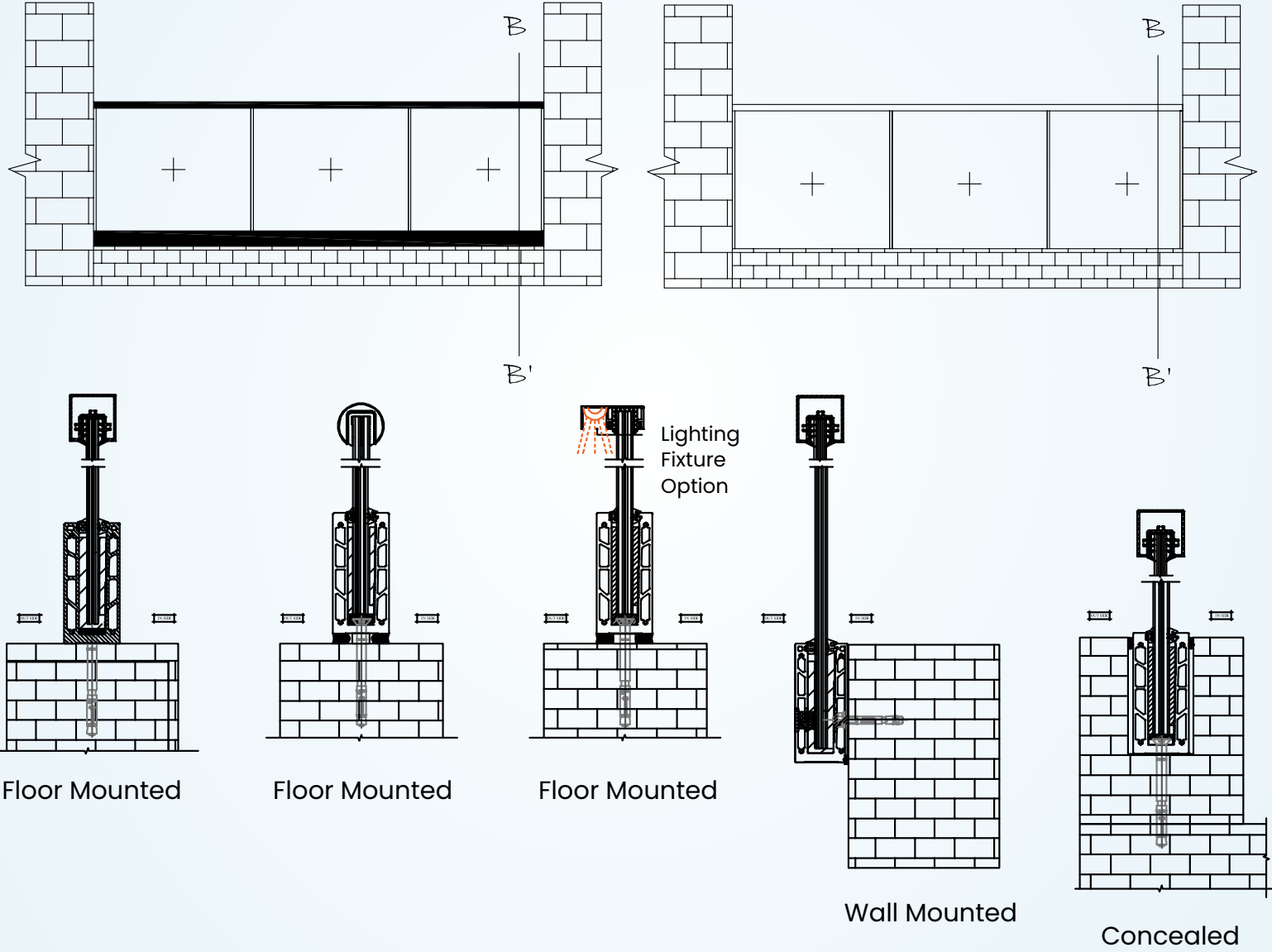



How Alteza Excels

An eye for detail is important because some customers may be looking for a reliable all-rounder. Others may be looking for more flexibility or a specially configured solution. While still some others may value innovative technology more. Then the aesthetically minded customers looking for an exceptionally slender window that can satisfy their most exacting architectural design requirements.

Alteza delivers an end-to-end solution that will fit perfectly without missing out on any of your needs. Our objective is to ensure that customers realise the maximum value addition at every phase of the project. The Alteza premium aluminium window and door collection includes an impeccable range of Casement, Sliding, Lift & Slide, Tilt & Turn, Slimline, Minimal frame and Bi-folding windows and doors, and more.

End-to-End Bespoke Solutions Alteza offers end-to-end service -- beginning with consultations, design, fabrication, installation and follow it up with post sale service support. Enabling architects and building owners drive rapid innovation, use advanced technologies and deliver building aesthetics that increases energy efficiency, raises comfort level and boosts value.

Wide Range of Solutions Alteza not only offers to customize a wide range of premium aluminium window and door systems but also makes total customization a reality. Alteza solutions range from simple applications, like Casement & Sliding systems to customized and precision-engineered applications like the highly complex Slide & Fold and Lift & Slide systems solutions.

Tested & Proven Expertise Alteza is a product of the combined expertise of Craft, a world leader with unmatched engineering, fabrication and design expertise, and Aparna Enterprises Limited, with an impeccable track record of delivering a complete systems solution, on-time and on-budget.

On-Time Project Completion Alteza also brings unparalleled simplicity to ensure on-time project completion by having a single point of contact, relying on one technical and customer service support team, and delivering the complete product solution package, designed around your specific needs, in one shipment, ready for installation.

10-Year Warranty Alteza is committed to offering products of the highest quality and fitted to the highest standards. All products come with a comprehensive warranty. The validity of the warranty is for 10 years, covers Alteza profiles and colour and 5 years for hardware products and all components of the windows and doors.

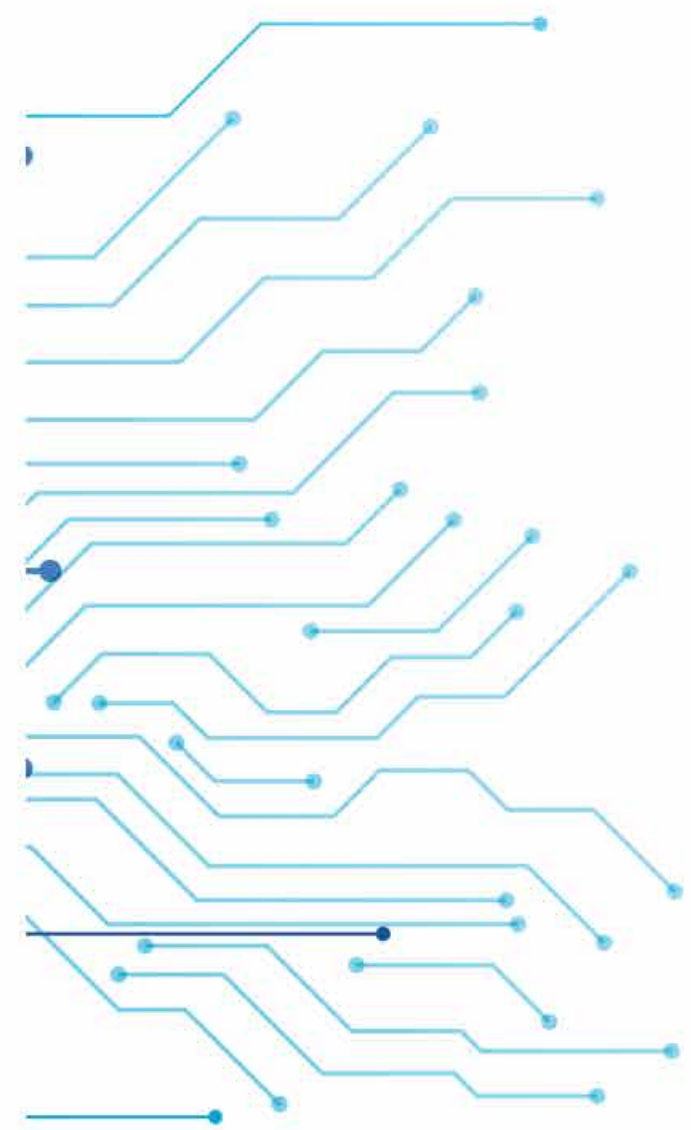

Built to Perform

Designed for high performance, Alteza premium aluminium windows and doors advantages play a key role in the transformation of the customer's vision into reality, shaping the building's exterior and interior. As well as delivering exceptional comfort levels and energy savings over the entire product lifecycle.

More Glass, Less Frame Alteza high performance aluminium windows and doors offer slim sightlines, clean edges and larger glass surface areas ensuring wider views with minimal obstructions. The seamlessly integrated glazing with customizable thresholds, create free-flowing spaces, blending the indoor with the outdoor in exquisite harmony.

Energy Efficiency All Alteza aluminium window and door profiles are designed specifically to prevent heat transfer through the frame. Low E glass reflects heat back into the atmosphere, minimizing interior heat gain and lowers the use of air-conditioners, helping reduce power bills by up to 30%! A gap within the double glazing, combined with a double-rebated design and double draft-resistant seals, minimizes heat gains and keeps the interiors cool and the noise out.

Robust & Durable Alteza aluminium windows and doors are highly resistant to all-weather conditions. They don't warp or rot and are termite-free. They are designed to bring low maintenance, durability, energy saving to life. The high strength to weight ratio makes them tough and withstand the roughest environmental conditions. They do not change their colour, shape, size, or lose their shine even after years of use.

Wind Resistance All Alteza structural glass assemblies are bespoke and designed with the correct glass thicknesses and strengthening inter layers. Alteza high performance aluminium windows and doors can easily withstand heavy wind loads, making them ideal for high-rise buildings and areas that are prone to high velocity winds.

Water Tight Alteza high-quality EPDM stop seals deliver what they promise, even after many years. The exceptionally weather-resistant material is highly resilient, and therefore guarantees long-term water tightness.

Strong & Extremely Secure Usage of virgin aluminium and multi-chambered design with thicker walls, ensures all Alteza high performance aluminium windows and doors are extremely strong and come with original multi-point locking systems. Alteza is designed to meet the highest levels of security and allows the incorporation of grills, providing extra assurance in regards to security and safety.

Noise Reduction Along with the many advantages of aluminium windows, Alteza also delivers exceptional sound insulating capabilities of up to 30 decibels by simply causing the sound wave to lose power. This is achieved by using materials that absorb and reflect all noise – like glazing, using double sealants, by building frames with thicker walls and by ensuring the frames are multi-chambered in order to combat noise.

Fire-Proofed Alteza aluminium windows and doors benefits includes its non-inflammable quality. The windows and doors do not cause or enhance the development of fire and are self-extinguishing by nature.

High Functional Reliability All load-bearing hardware components such as hinges are bolted in at several points. This ensures superior and long lasting functionality and high durability for your window and door, even when using the heavy triple glazed system, and ensure smooth operation. The heavy-duty nylon roller and the high quality hardware ensures the smooth movement and functioning of the window and door systems.

The Best Finish There is a huge variety and difference in the quality of the aluminium windows and doors that are available. Alteza uses only prime billets in the manufacture of its profiles, and not the recycled aluminium extracted from scrap metal. Then after each extrusion run, every die is polished to eliminate contamination on the surface. This why all Alteza products have a smooth, consistent and a high quality finish.

Full Range of Colours Alteza high performance aluminium windows and doors offer high quality finishes including polyester powder coat paint finish in a wide range of colours and anodizing finish in both solid and metallic colours, providing outstanding resistance to environmental conditions.

Customized Solutions Alteza brings home all the aluminium windows and doors advantages one can expect. You can even customize them to any specification and configuration you want. Alteza provides a full end-to-end service from consultations and specifications through delivery and installation.

Easy to Maintain Alteza aluminium windows and doors have been designed for low maintenance, durability, energy saving and lifelong performance. Alteza aluminium doors and windows do not rust and maintaining them is quick, easy and inexpensive.

Environmental Friendly Aluminium is one of the most environmentally friendly metals on the planet. 100% of the metal can be recycled, and this saves 95% of the energy required to produce aluminium from raw materials. Aluminium can be recycled again and again, forever.

Alteza End-to-End Process

Design Consultation & Survey Whether you order one aluminium window/door or thousands, we'll customize the perfect aluminium windows and doors solution for you. As a matter of fact, being one of the leading aluminium windows and doors manufacturer in the country, we start our one-on-one consultations process right at the beginning, when we are pitching for the project. After the design and specification are approved, our team of survey executives, armed with precision optical instruments, begin the physical assessment and take exact measurements of the vents for windows and doors.

Fabrication Alteza uses only virgin aluminium and the highest quality, branded original components, high quality glazing and reliable and proven hardware. Right from using world-class European technology to ensuring quality workmanship, Alteza ensures top-notch quality goes into the premium aluminium windows fabrication process at every step.

Delivery After the fabrication process is completed, each product is individually wrapped and packed to eliminate the chances of damage during transit and delivers at site as per the agreed delivery schedule.

Installation Alteza end-to-end process continues beyond just the fabrication and delivery. Our expert installation team takes care of even minute disorientations and ensures flawless installation of systems. Our Installation team tests your newly installed windows and doors and checks all the joints, channels, hardware, glazing etc before handing it over to you.

Post-Sale Service Once the handover is complete, Alteza customer support team is in a standby mode, ready to be activated to resolve any issue – this service is FREE for the first year. Alteza post-sale service support covers all functional issues to your Alteza premium aluminium window and door system –FREE of cost for the first 12 months of the installation.



Types of Glass

There are many types of glass you can opt for when choosing your customized aluminium windows and doors. Right from a clear glass to toughened glass, from glass that is 5mm thick and goes up to 12mm. The type you choose depends on your requirements and purpose. Rest assured any type of glass you select will be a well-known brand that delivers quality.

Performance glass acts like a protection against harmful UV rays entering into the interiors. You could consider opting for a tint for your customized aluminium windows for many reasons. As a design element, for aesthetics, and for reducing heat from sunlight. People usually use a tint to reduce the intensity of the glare of white light, as well as to increase the sense of privacy.

Clear This glass ensures high-clarity and is traditionally used for aquariums, display cases and some customized aluminium windows, where extra clarity is desired. Bear in mind, opting for this type of glass, means allowing more heat into your home. Technically, this type is called 'float glass', so named because molten glass is floated on molten tin, producing the smoothest possible large, thin glass sheets and panels. This is a basic type of glass, low-cost, colourless and clear glass meant for windows, glass doors and panels.

Frosted Translucent glass allows the light to pour into the interiors, but cannot be clearly seen through. It is designed as privacy glass, typically used for bathroom customized aluminium windows, shower doors and anywhere else where privacy is desired. Patterns are available in numerous designs, including etched and coated, with different levels of privacy to suit your needs.

Toughened Customized aluminium window designs might demand the use of extra strong glass. Also known as tempered glass, it is five times stronger than regular glass. This type of glass is designed to break into small blunt pieces under pressure, making it much safer than shards of normal glass. It also helps insulate interiors from heat, sound and shock waves. Ideally suited for balcony doors and windows, shower enclosures and for display windows.

Laminated Alteza customized aluminium systems offer laminated glass for windows and doors. This type of glass is extra-strong, and provides greater security. It is created by fusing at least two panes around an inner layer of PVB (polyvinyl butyral). This thin plastic interlayer between two panes of glass increases insulating properties, improves resistance against damage, and if and when the glass breaks, the glass doesn't shatter. The thin plastic layer will hold all the dangerous shards together.





Choice of Glazing

Is your office or home located in a noisy neighbourhood? Are your interiors getting too hot during summers and stay too cold in winters? Is your electricity bill shooting through the roof? Then double-glazing your customized aluminium windows will be the perfect solution. The benefits you get in return far outweigh the cost.

Single Glazing: A single glazed window contains just one single pane of glass. While this keeps costs low, its insulative capability will be poor.

Double Glazing: Double glazing your Alteza customized aluminium windows and doors is a better option as this makes the glass stronger, shatterproof, and clearer. Improves energy efficiency, security, and even reduces noise levels.



Nothing Beats an Original

All Alteza customized aluminium windows and doors are fitted with only original hardware and this is never compromised. So no matter what type of Alteza customized aluminium systems you buy, you are rest assured of parts that go into it.

Right from the handles to locks, from steel bars to shootbolts, from friction hinges to security enhancing restrictors, and even the high performance automatic blind closing and opening systems, they are all manufactured by OEMs and meet strict Alteza standards that surpass international norms.

The image shows a large window with a mesh screen and a view of a golf course with trees. The window is framed in a dark color and has a handle on the left side. The mesh screen is made of a fine, diamond-shaped pattern. The view outside the window shows a green golf course with several large, mature trees in the foreground and a clear blue sky in the background. The window is set in a wall that appears to be part of a building with a modern design.

Let Fresh Air In

Alteza customizes even the mesh to create a relaxed environment by retaining privacy and allowing fresh air to circulate within the interiors on a warm day or night. The quality of the mesh used for Alteza customized aluminium windows and doors ensures stability of the mesh in extremely corrosive environments as well as when exposed to high temperatures.

SS Mesh The SS mesh used by Alteza customized aluminium windows and doors is very durable and characterized by the extremely low variance of the pore size and by the high stability of the pore geometry. It provides a protective screen without compromising the aesthetics.

Fiber Mesh Alteza customized aluminium windows and doors uses only high quality fiber mesh crafted for maximum protection; they have the necessary dimensional stability and durability, and are washable.

Colour Palette

For one person, colour is a means of personal expression, for another a beautiful colour shade is an extremely personal aesthetic experience and for a third, a particular colour may trigger certain pleasant and happy memories.

Irrespective of what colour means for you and which colour you like the most, with Alteza you can indulge and express your individual taste to its fullest.

Alteza offers high quality finishes including powder coating, anodizing finish in both solid and metallic colours, providing outstanding resistance to environmental conditions.

Anodizing in 6 Colours

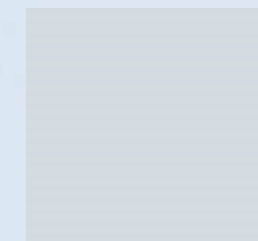

Silver Matt

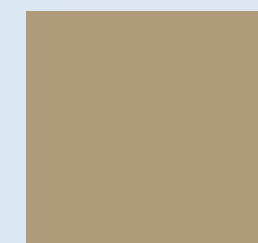

Champagne

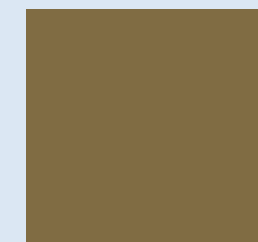

Light Bronze



Medium Bronze

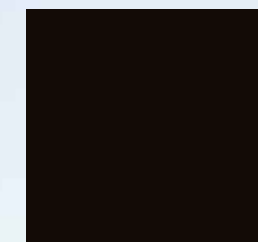

Dark Bronze

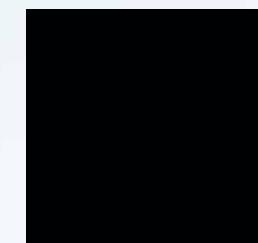

Black

Powder Coating Options:

100+ RAL colours

Wood Finish:

Natural wood-looking finish available in 25 different shades

Service That is Second to None

Alteza offers the all-in-one service solution, including aluminium windows and doors installation. Alteza's drive to enhance its service support quality begins from its commitment to closely supervise the entire installation process and follow this up with efficient post sales service for windows and doors that are monitored for quality. Trained technical and maintenance teams are on-call and available 365 days a year for all services, including delivery and installation.

Professional Installation Our dedicated team of trained professionals take the time to understand your requirements and provide a unique solution for your needs. The delivery and installation of new aluminium doors and windows is always a smooth process that is completely hassle-free to the customer.

Hassle-Free Service We also keep a close check on the performance of our products, even after we install aluminium doors and windows. In case you have any concerns regarding the performance of our products, you can raise a request at any time and our expert technicians will also provide excellent post sales service for windows and doors and resolve your issue in no time.

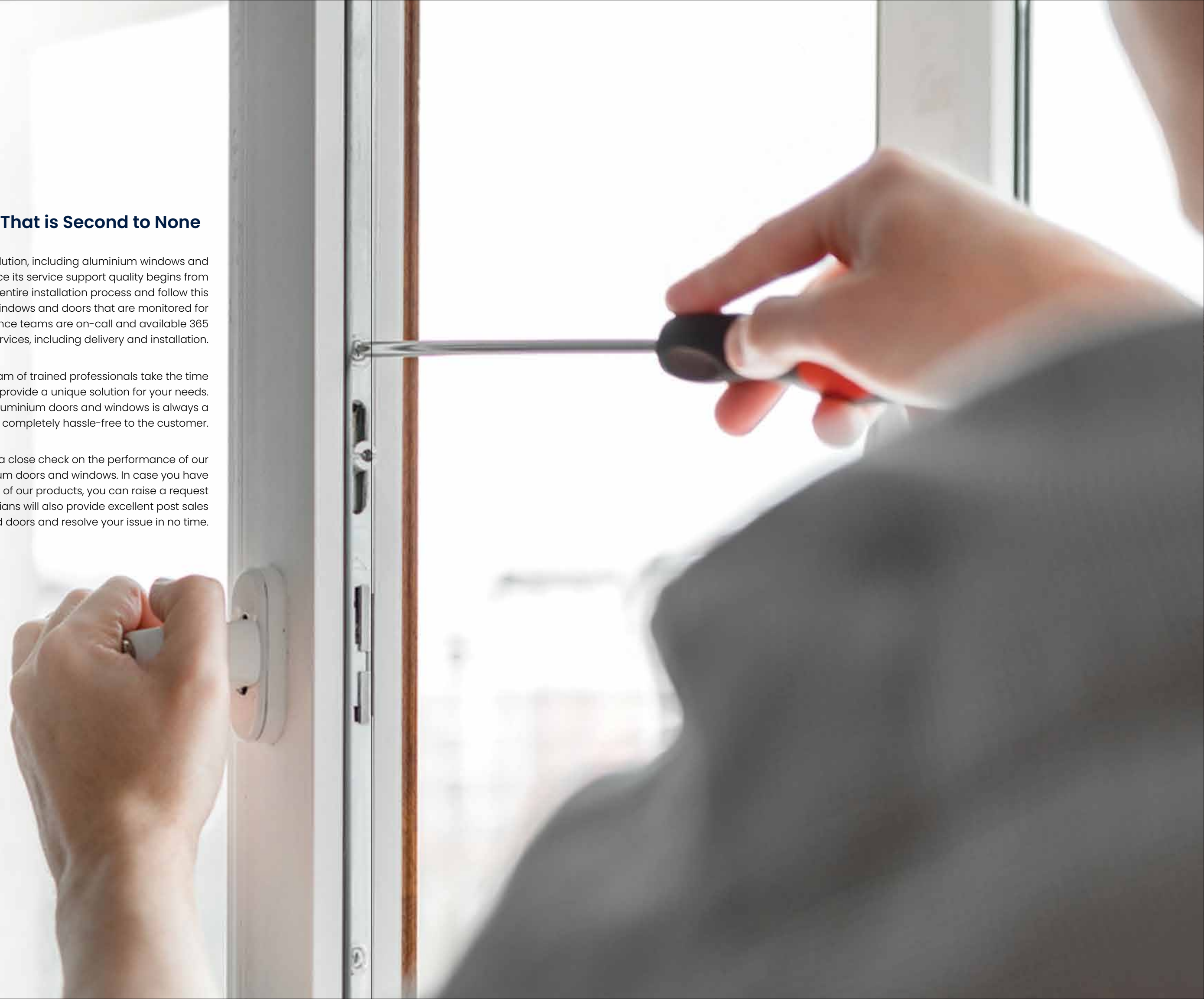

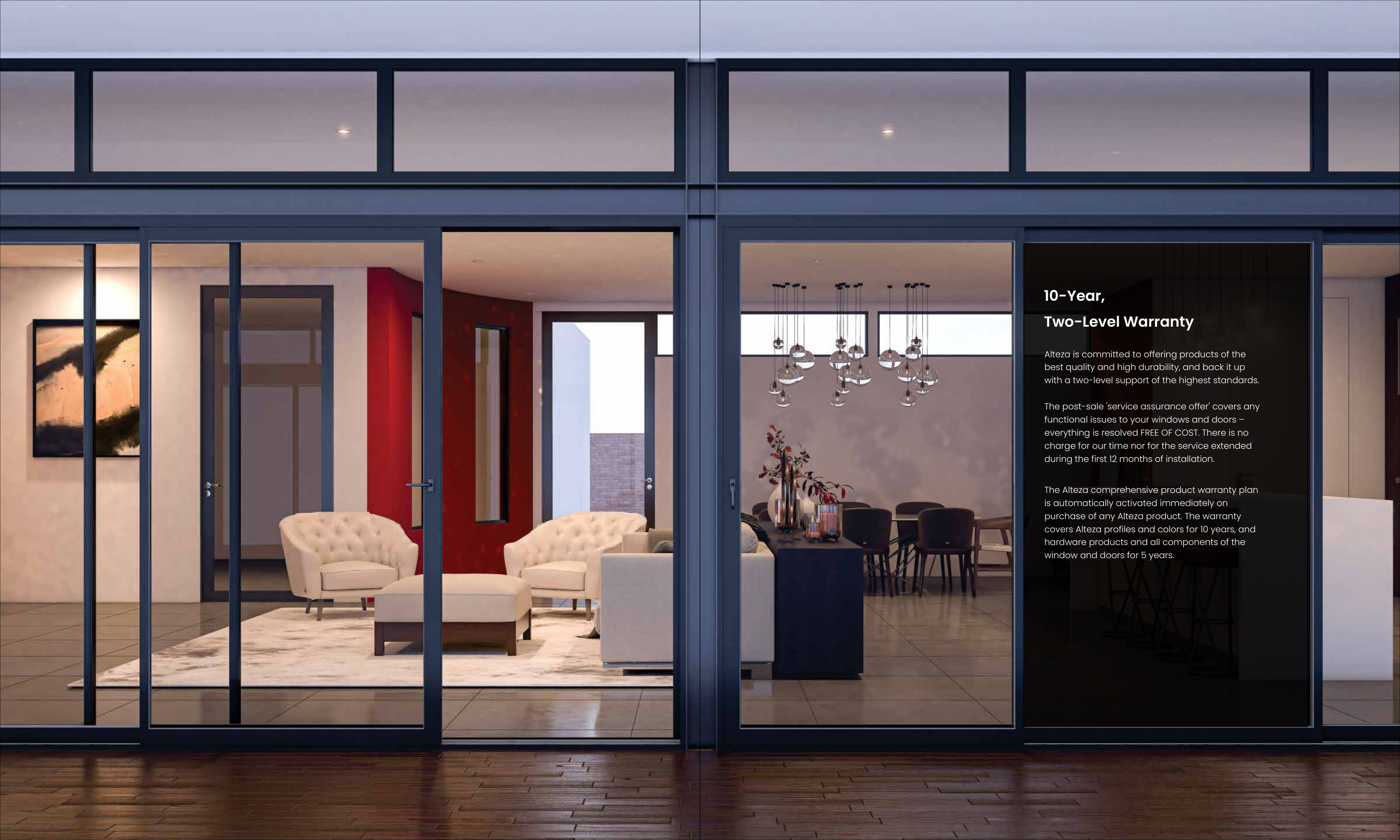

10-Year, Two-Level Warranty

Alteza is committed to offering products of the best quality and high durability, and back it up with a two-level support of the highest standards.

The post-sale 'service assurance offer' covers any functional issues to your windows and doors – everything is resolved FREE OF COST. There is no charge for our time nor for the service extended during the first 12 months of installation.

The Alteza comprehensive product warranty plan is automatically activated immediately on purchase of any Alteza product. The warranty covers Alteza profiles and colors for 10 years, and hardware products and all components of the window and doors for 5 years.



The People Behind Alteza

APARNA-CRAFT is the complete systems solution provider to offer precision engineered premium aluminium window and doors in India. Backed by a hard to beat "on-time, on-budget" project completion promise.

APARNA-CRAFT is a joint venture between Aparna Enterprises Limited, a leader in building material products and Craft Holdings Ltd, Hong Kong. A world leader with unmatched engineering, fabrication and design expertise, involved with prestigious projects across the globe.

Together, they make an uncompromising proposition that ensures every Alteza product delivers flawless functionality and performance throughout its lifetime.